



# MOTOGEN

## TECHNICAL SPECIFICATIONS

PARAMETERS	Value
Type	90SLC2
Frame Size	90SL
Frequency (Hz)	50
Phase	3
KW	2.2
HP	3
Voltage (V)	230Δ/400Y
Current (A)	4.19Y
RPM	3000
Rated Speed (RPM)	2871
Torque (N.m)	7.3
P.F	0.9
Is / In	7.5
Ts / Tn	2.7
Frame Material	Cast Iron
IM	B35
IP	55
Ins.Class	B/F
J (Kg.m2)	0.0014
Driven End-Bearing	6201-2Z
Non-Driven End-Bearing	6201-2Z
Stator Winding	Copper



**Electromotor 90SLC2 2.2-3000 EExdIICT4 55F B35  
:installation Method**



Dimensional specification of Flameproof electromotors frame size 80-132

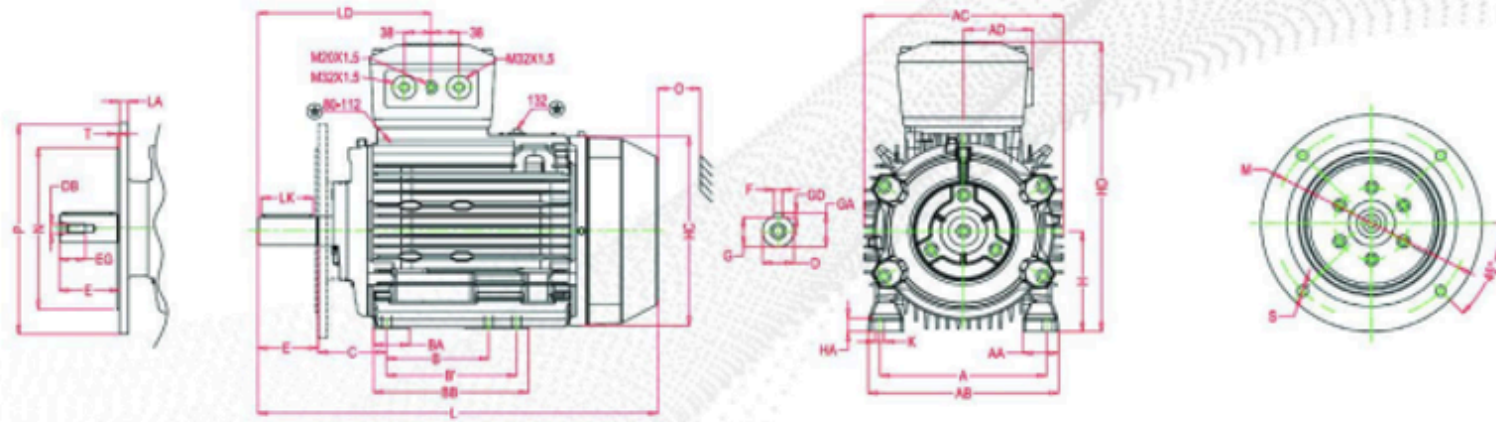

Motor size	A1	B1	H1
EEx d 80-132	175	170	115
Eex de 80-132	210	188	63

Terminal box dimensions

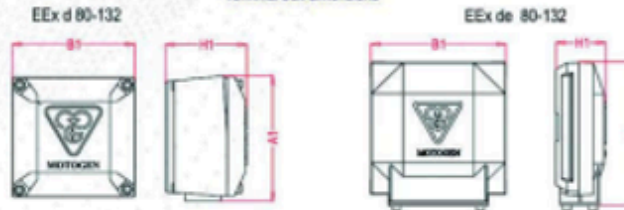

Motor size	Flange dimensions			
	P	M	N	S
80-90	200	165	130	M10
100-112	250	215	180	M12
132	300	265	230	M12

Cable glands sizes اندازه های گنند کابل

Frame size	Metric threads
80-90	1×M20×1.5+1×M25×1.5
100-132	1×M20×1.5+2×M32×1.5

Motor size	Poles	A	AA	AB	AC	AD	E	B'	BA	BB	C	D	DB	E	EG	F	G	GA	GD	H	HA	HC	HD	K	L	LD	O	LK
80M...	2-8	125	34	160	175	92	100	125	32	150	50	19	M6	40	16	6	15.5	21.5	6	80	10	160	300	10	340	170	20	32
90SL...	2-8	140	34	175	195	92	100	125	32	150	56	24	M8	50	19	8	20	27	7	90	10	190	315	10	405	180	20	40
100 L...	2-8	160	45	220	215	92	140	-	41	170	63	28	M10	60	22	8	24	31	7	100	10	210	335	12	440	194	25	50
112 M...	2-8	190	45	220	215	92	140	-	39	170	70	28	M10	60	22	8	24	31	7	112	15	210	350	12	440	194	25	50
132 SM...	2-8	216	44	245	275	92	140	178	48	210	89	38	M12	80	28	10	33	41	8	132	17	265	390	12	540	234	30	70

