

eLION motor EMS1-16



- ▶ Permanent magnet synchronous reluctance motor (PMSRM)
- ▶ Nominal power range: 39 to 144 kW
- ▶ Continuous torque: up to 705 Nm
- ▶ Maximum speed range: 5500 rpm
- ▶ Nominal voltage range from 400 to 750 VDC
- ▶ High operational efficiency (max. > 96%)
- ▶ Protection class IP6K7 to IP6K9K
- ▶ Ambient temperature range: -40 to +100 °C
- ▶ Fluid cooled with inlet temperature up to 65 °C
- ▶ Motor and generator operation

Features

- ▶ Modular and scalable design based on diameter, length, and number of windings
- ▶ Heavy-duty design for off-highway applications
- ▶ Designed for various functions including travel, working, and slew drives, etc.
- ▶ Standardized mechanical interface for direct gear unit, ICE, or pump connection
- ▶ Resolver as a robust feedback sensor

Contents

Motor selection overview	2
Product description	3
Ordering code	4
General technical data	6
Technical data EMS1-16	7
Power data EMS1-16	9
Sensor	57
Electrical connections	58
Operating ranges and characteristic curves	59
Dimensions	60
Mounting type	66
General	66

Motor selection overview

The EMS1 torque and power overview provides an overview of the torque and power of the EMS1-16 motors at a nominal voltage of 700 VDC.

The chapters “General Technical Data”, “Technical Data EMS1-16” contain detailed values and characteristic curves for each motor size, length and winding.

▼ Torque and power overview EMS1

eLION motor typ	Length	Maximum rotational speed ▶		Up to 5500			
		n_{max} [rpm]		1000	1500	2000	2500
		Nominal rotational speed ▶					
		n_{nom} [rpm]					
		Torque ▼		Continuous power ³⁾ ▼			
		M_0 [Nm] ²⁾	M_{max} [Nm]	P_{nom} [kW]			
EMS1-16	F	393	707	39	58	77	90
	H	524	943	51	76	98	114
	J	638	1178	63	90	117	134
	L	748	1413	74	105	135	141

1) See chapter “Technical data”

2) M_0 stands for “torque at low rotational speed”

3) Calculated with a voltage of 700 VDC

Product description

The eLION EMS1 motor is a permanent magnet synchronous reluctance motor. It is designed for the harsh environments where off-highway machines are used. The motor is available with two different diameters and with variable length and nominal speed. The product range is currently being expanded with two additional diameters.

Due to its mechanical design, the motor can be adapted to various machine functions, e.g. traction, gearbox connection, axle connection, and electrohydraulic devices.

Selection of the frame size, length, and winding of the motor

The thermal equivalent torque (RMS torque) and the average rotational speed of the load cycles are required to select the right motor. This simplified calculation does not take into account the thermal time constant of the motor. It is sufficient if the overload time of each section of the torque requirement is shorter than the thermal time constant of the motor. For the calculations, the load must be separated into sections with torque over time. The equivalent thermal torque can be calculated using the following formula:

$$M_{\text{RMS}} = \sqrt{\frac{1}{T} \times \sum_{i=1}^n M_i^2 \Delta t_i}$$

$$n_{\text{avg}} = \frac{1}{T} \times \sum_{i=1}^x n_i \Delta t_i$$

The thermally equivalent torque can then be inserted into the torque-rotational speed diagram of the selected motor. This operating point must then be below the curve M_{S1} . All operating points of the load cycles must be within the maximum torque and speed capabilities of the motor.

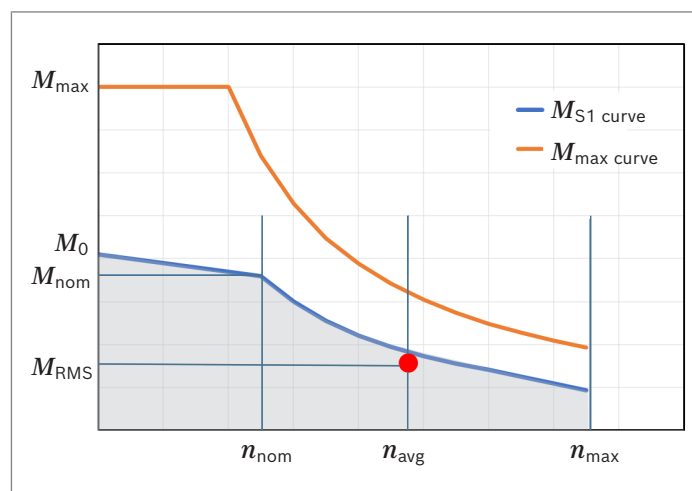

Ordering code

01	02	03	04	05	06	07	08	09	10	11	12	13	14	15	16			
EMS1	-	16		L	M7	-	R	S		-		N	N	NNNN	-	NN	-	NN

Produkt

01	eLION motor	EMS1
----	-------------	------

Axle height

02	200	16
----	-----	----

Length

03	Active length 180 mm	F
	Active length 240 mm	H
	Active length 300 mm	J
	Active length 360 mm	L

Nominal rotational speed

04	1000 rpm	10
	1500 rpm	15
	2000 rpm	20
	2500 rpm	25

Cooling

05	Liquid cooling	Connection G1/2	L
----	----------------	-----------------	---

Design

06	Motor, 700 V	M7
----	--------------	----

Encoder type

07	Resolver	R
----	----------	---

Encoder design

08	Single turn, 1 rotation, absolute	S
----	-----------------------------------	---

Electrical connection

09	Terminal box	Single input UVW, input direction A/B	AB
----	--------------	---------------------------------------	----

Shaft/hub design

10	External spline shaft for motor (according to DIN 5480)	W 50 × 2 × 24 × 8c	W3
	Internal splined shaft 2 for pumps (according to ANSI B92.1)	N1 1/4 14T 12/24 DP	N2
	Internal splined shaft 4 for pumps (according to ANSI B92.1)	N1 3/4 13T 8/16 DP	N4

Flange

11	Motor flange (according to SAE J617)	SAE 4	M4	
	Pump flange (according to SAE J744)	SAE C4/C2 +	Motor flange (according to SAE J617) SAE 4, 90° steps	P7
	Pump flange (according to SAE J744)	SAE D4 +	Motor flange (according to SAE J617) SAE 4, 45° steps	P8

Bearing

12	Standard	N
----	----------	---

Mounting type

13	Flange mounting B5, including threaded holes for foot mounting B35	N
----	--	---

Attachments / Equipment

14	Standard	NNNN
----	----------	------

01	02	03	04	05	06	07	08	09	10	11	12	13	14	15	16				
EMS1	-	16			L	M7	-	R	S		-		N	N	NNNN	-	NN	-	NN

Coating / Label

15	No coating, standard label	NN
	No coating, individual label	MN
	Standard coating, standard label	BN
	Standard coating, individual label (see data sheet 90314 "Standard coating of axial piston units")	CU

Other version

16	Standard	NN
----	----------	-----------

▼ **Possible shaft/hub flange combinations**

Shaft/hub	Flange		
	M4	P7	P8
W3	●	-	-
N2	-	●	-
N4	-	-	●

● = possible - = not possible

General technical data

The technical data are standard values. The tolerances that occur due to deviations of electrical properties can be found in the section “General tolerances”.

The shown data are for a DC-voltage of 700VDC.

Please contact your local sales representative for data sheets with other voltages.

General tolerances

The values specified in the technical data are subject to natural dispersion. For the following parameters, the tolerance specifications must be observed.

Designation	Symbol	Tolerance value
S1 continuous torque at 200 rpm	$M_{S1, niedrige}$ Drehzahl	±5 %
S1 continuous torque at n_{nom}	$M_{S1, n_{nom}}$	±5 %
S1 continuous power at n_{nom}	$P_{S1, n_{nom}}$	±5 %
S2 for 60 s torque (maximum torque)	$M_{S2, 60 s}$	±5 %
Maximum short circuit braking torque	$M_{max, sc}$	±5 %
Phase-phase voltage constant at 20 °C	k_{EMK}	±5 %
Torque constant at 25 °C	k_T	±5 %
Rotor inertia	J_{rot}	±10 %

Operating environment conditions

Parameter	Unit	Value
Ambient temperature range according to ISO 16750-4	°C	-40 ... +100, code J
Climatic, according to ISO 16750-4		Code O
Relative humidity according to IEC 60068-2-38	°C	25±2 K at 80 ... 96% relative humidity 25±2 K at 93±3% relative humidity 55±2 K at ≤ 20% relative humidity 65±2 K at 93±3% relative humidity Tested: in 10 cycles of 24 h each
Protection class according to ISO 20653	open shaft assembled unit	IP6K7 IP6K9K
Vibration (sinusoidal) ¹⁾	g	6 RMS (10 ... 2000 Hz) ²⁾ Tested: 8 h per axis
Shock (non-recurring)	g	50 (11 ms) ²⁾ Tested: 3 shocks in all directions and axes (total: 18 shocks)
Shock (recurring)	g	25 (6 ms) ²⁾ Tested: 1000 shocks in all directions and axes (total: 6000 shocks)
Maximum altitude above sea level (NHN)		Up to 4000 m above sea level without power reduction
Chemical loads, based on ISO 16750-5		Code A and code D Additional fluids tested: Saltwater, motor oil, gear oil, rear axle oil, power steering fluid, brake fluid, axle grease, washing solvent, gasoline, diesel, biodiesel, isopropyl alcohol, antifreeze ethylene glycol cleaning agent, battery acid, fuel additives, kerosene, dust control (magnesium chloride), humidity control (calcium chloride), hydrochloric acid, fertilizer -28% nitrogen, herbicide, fungicide, ether, bleach solutions, primer, BASF G40 antifreeze, Shell universal cleaner

1) At the respective natural frequency in the range of ±30 Hz, the specified excitation is lower..

2) Lengths F and H in flange mounting; lengths J and L in foot mounting

Technical data EMS1-16

General electrical properties

Parameter	Unit	EMS1-16			
		10	15	20	25
Nominal rotational speed	rpm	1000	1500	2000	2500
Maximum rotational speed	rpm	5500			
Nominal voltage range	VDC	400 ... 750			
Operating DC voltage	VDC	270 ... 850			
Voltage range		HV_3 according to LV123			
Switching frequency	kHz	≥ 4			
Electrical connection		Star connection			

General mechanical properties

Parameter	Unit	EMS1-16				
		F	H	J	L	
Weight	Internal splined shaft	kg	162,2	188,1	214,3	240,2
	External spline shaft	kg	163,7	189,7	216,0	241,9
Overall length	mm	448	508	568	628	
Moment of inertia	Internal splined shaft	kgm ²	0,137	0,178	0,219	0,26
	External spline shaft	kgm ²	0,142	0,183	0,224	0,26
Center of gravity	Internal splined shaft	mm	X = 172.9 Y = 8.7 Z = -0.37	X = 202.4 Y = 7.6 Z = -0.32	X = 232.2 Y = 6.8 Z = -0.28	X = 261.8 Y = 6.0 Z = -0.25
			External spline shaft	mm	X = 176.7 Y = 8.9 Z = -0.37	X = 206.1 Y = 7.7 Z = -0.32

Mechanical interface

Parameter	
Motor mounting	
Motor flange (according to SAE J617)	SAE 4
External spline shaft (type code W3) for motor (according to DIN 5480)	W 50 × 2 × 24 × 8c
Pump mounting	
Pump flange (according to SAE J744)	SAE C4 / C2, 90°-Schritten
Internal splined shaft (type code N2) for pumps (according to ANSI B92.1)	N1 1/4 14T 12/24 DP
Pump mounting	
Pump flange (according to SAE J744)	SAE D4, 45°-Schritten
Internal splined shaft (type code N4) for pumps (according to ANSI B92.1)	N1 3/4 13T 8/16 DP

Cooling

The table shows the operating conditions for the cooling liquid. Further information on motor cooling can be found in “Operating Instructions 96709-01-B”.

Parameter	Symbol	Unit	Value
Standard cooling liquid			Water:glycol 50:50 – Glysantin G40
Nominal flow rate	Q_{min}	l/min	20
Maximum inlet pressure	p_{max}	bar	6
Inlet temperature	T_{inlet}	°C	Minimum -37 °C Maximum 65 °C
Cooling liquid volume	Length	F	V_{liquid} l 0.9
		H	V_{liquid} l 1.1
		J	V_{liquid} l 1.3
		L	V_{liquid} l 1.4
Coolant channels material			Aluminium, cast iron
Coolant connection			2 × G1/2" according to ISO 1179-1
Heat class according to IEC 60034-1			H

Pressure drop

The following graphs show the pressure drop at a 50:50 water to glycol ratio depending on the flow rate and the temperature of the cooling liquid

▼ EMS1-16F

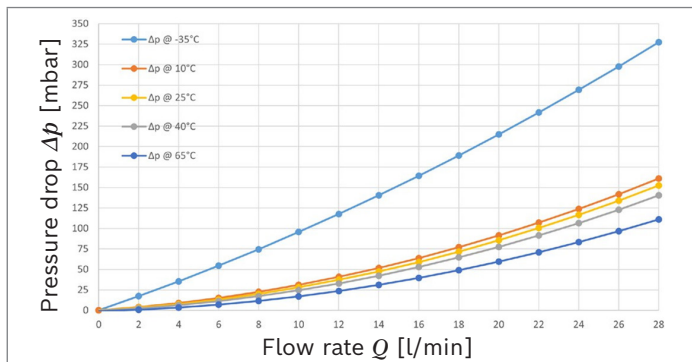

▼ EMS1-16J

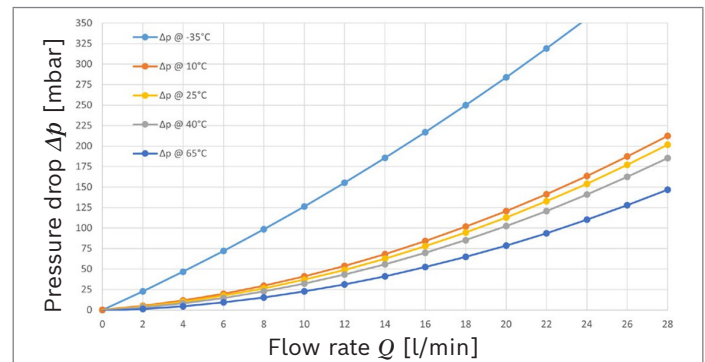

▼ EMS1-16H

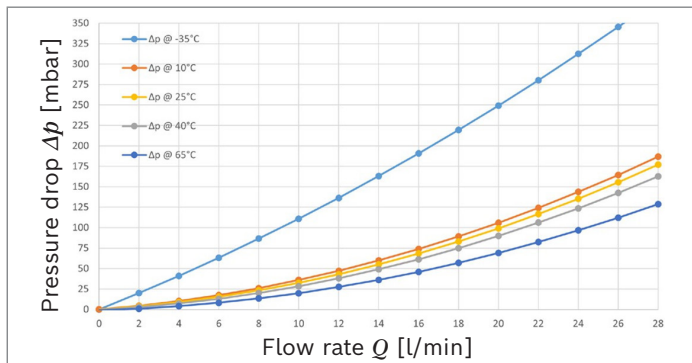

▼ EMS1-16L

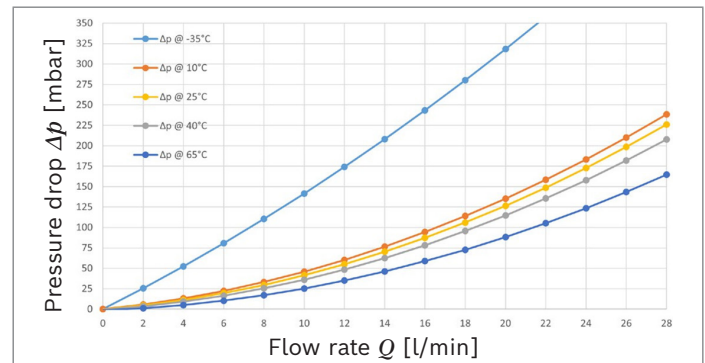

Power data EMS1-16

EMS1-16F10

Designation	Symbol	Unit	Value
S1 continuous torque at 200 rpm	$M_{S1, \text{low rotational speed}}$	Nm	393
S1 continuous current at 200 rpm	$I_{S1, \text{low rotational speed}}$	A _{RMS}	60
Nominal rotational speed	n_{nom}	rpm	1000
S1 continuous torque at n_{nom}	$M_{S1, n_{\text{nom}}}$	Nm	372
S1 continuous current at n_{nom}	$I_{S1, n_{\text{nom}}}$	A _{RMS}	59
S1 continuous power at n_{nom}	$P_{S1, n_{\text{nom}}}$	kW	39
S1 continuous efficiency at n_{nom}	$\eta_{S1, n_{\text{nom}}}$	%	91.34
S2 for 60s torque (maximum torque) ¹⁾	$M_{S2, 60 \text{ s}}$	Nm	711
S2 for 60s current (maximum current) ¹⁾	$I_{S2, 60 \text{ s}}$	A _{RMS}	127
S2 for 60s power (maximum power) ¹⁾	$P_{S2, 60 \text{ s}}$	kW	58
Maximum rotational speed	n_{max}	rpm	5500
S1 continuous torque at n_{max}	$M_{S1, n_{\text{max}}}$	Nm	2
S1 continuous current at n_{max}	$I_{S1, n_{\text{max}}}$	A _{RMS}	9
S1 continuous power at n_{max}	$P_{S1, \text{max}}$	kW	1
S1 continuous efficiency at n_{max}	$\eta_{S1, n_{\text{max}}}$	%	14.42
S1 continuous torque at $P_{S1, \text{max}}$	$M_{S1, P_{\text{max}}}$	Nm	233
S1 continuous current at $P_{S1, \text{max}}$	$I_{S1, P_{\text{max}}}$	A _{RMS}	59
S1 continuous power at $P_{S1, \text{max}}$	$P_{S1, P_{\text{max}}}$	kW	43
S1 continuous speed at $P_{S1, \text{max}}$	$n_{S1, P_{\text{max}}}$	%	1760
S1 continuous efficiency at $P_{S1, \text{max}}$	$\eta_{S1, P_{\text{max}}}$	%	91.82
Short circuit braking torque at nominal rotational speed ²⁾	$M_{\text{nom, sc}}$	Nm	28
Short circuit current at nominal speed ²⁾	$I_{\text{nom, sc}}$	A _{RMS}	67
Maximum short circuit braking torque ²⁾	$M_{\text{max, sc}}$	Nm	240
Maximum short circuit current ²⁾	$I_{\text{max, sc}}$	A _{RMS}	67
DC supply voltage	V_{DC}	V	700
Voltage for motor phases (outer conductor-outer conductor – RMS)	V_{LL}	V _{RMS}	475

Electric	Symbol	Unit	Value
Number of poles			8
Phase-phase voltage constant at 20 °C	k_{EMK}	V _{RMS} / 1000 rpm	343.8
Torque constant at 25 °C	k_{T}	Nm / A _{RMS}	6.72
Synchronous inductance (d-axis) at rated current	L_{d}	mH	6.48
Synchronous inductance (q-axis) at rated current	L_{q}	mH	19.41
Stator winding resistance (phase) at 20 °C	R_{LL}	Ω	0.405
Cogging torque (unskewed)	M_{cog}	Nm	12.06
Torque ripple	$M_{\text{Pk-Pk}}$	Nm	9.56

1) For the S2 calculation, the starting temperature of the components is assumed to be 25 °C.

2) Magnet temperature at 20 °C

▼ **Torque EMS1-16F10**

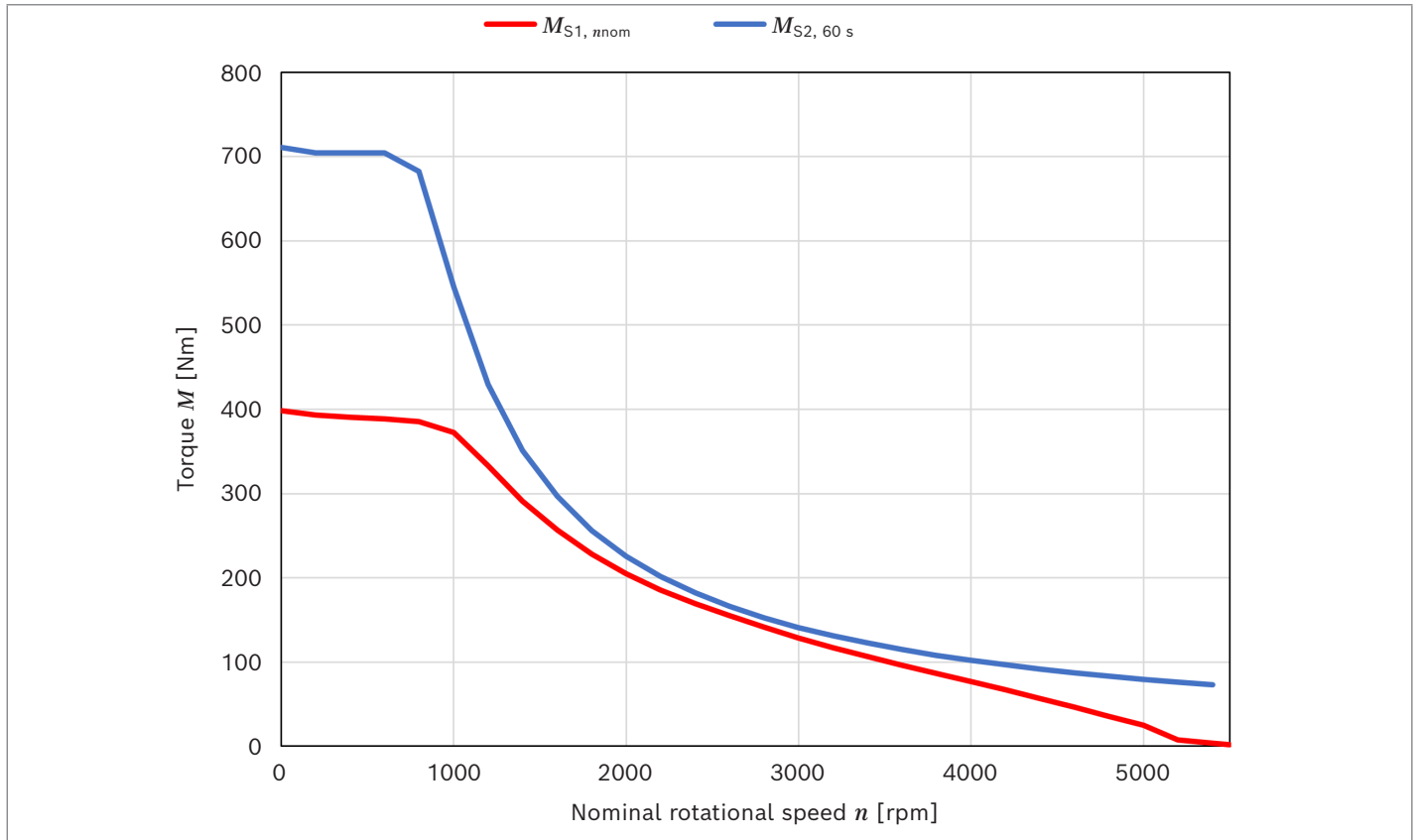

▼ **Power EMS1-16F10**

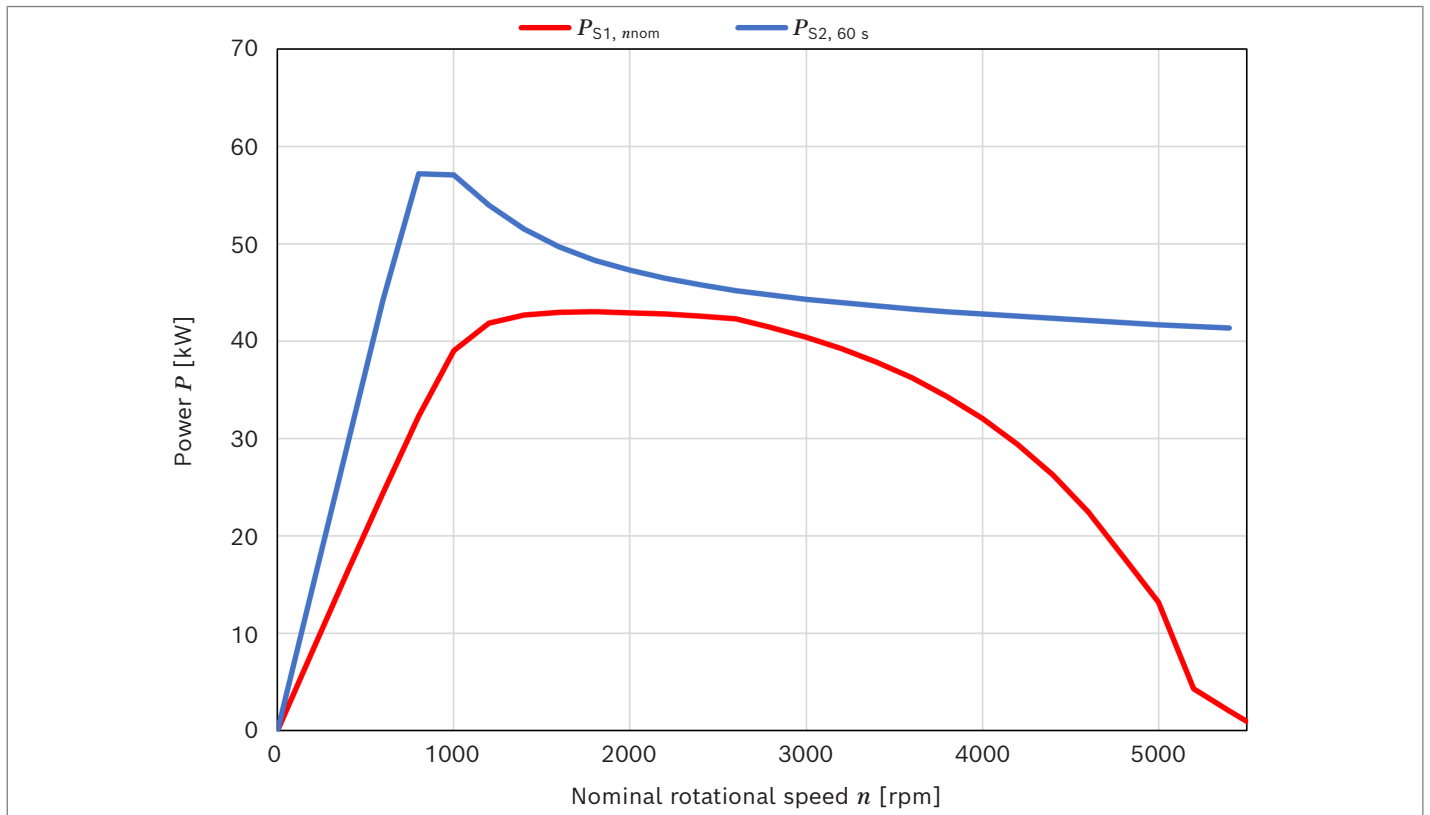

▼ Short circuit current and short circuit braking torque EMS1-16F10

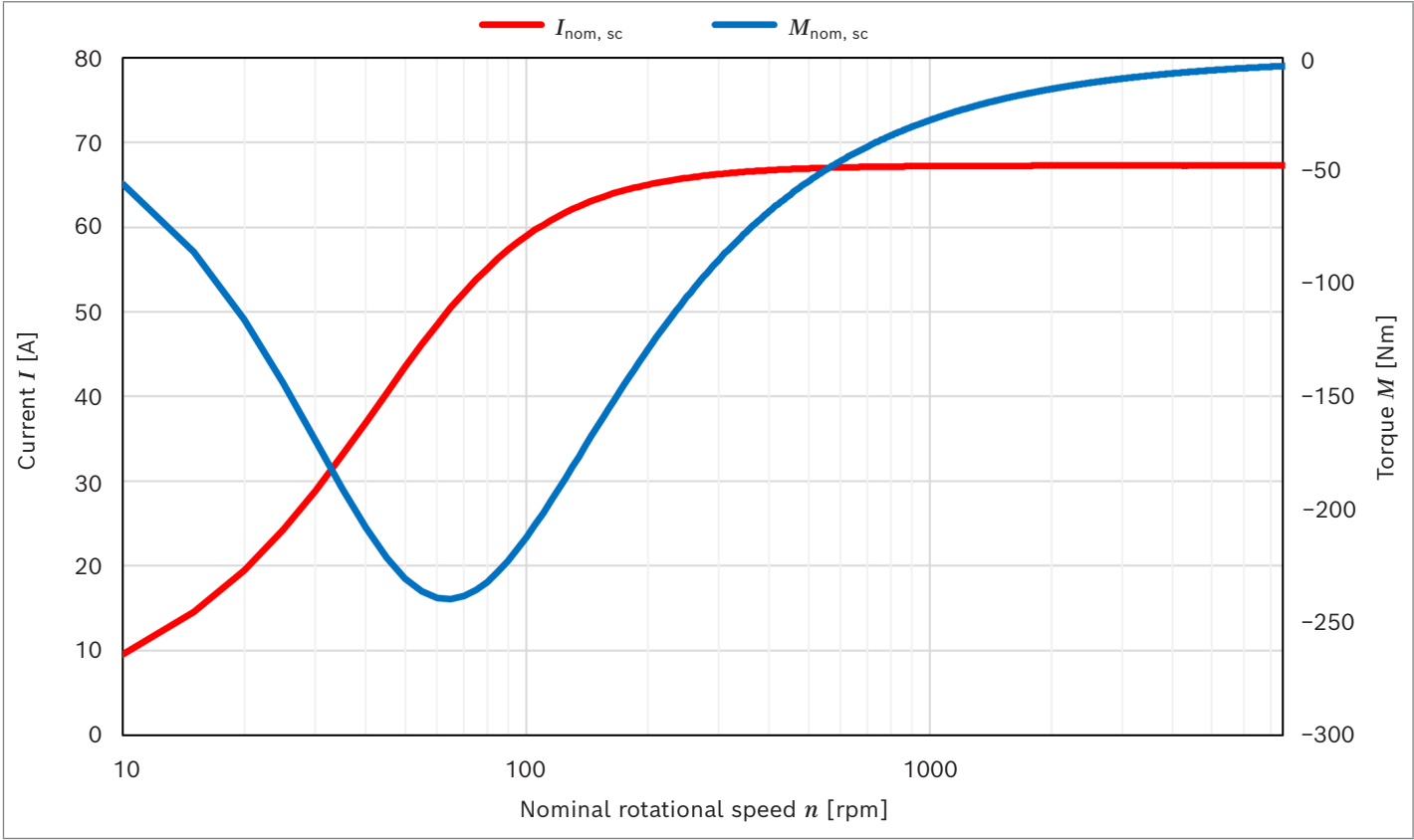

EMS1-16F15

Designation	Symbol	Unit	Value
S1 continuous torque at 200 rpm	$M_{S1, \text{low rotational speed}}$	Nm	397
S1 continuous current at 200 rpm	$I_{S1, \text{low rotational speed}}$	A _{RMS}	93
Nominal rotational speed	n_{nom}	rpm	1500
S1 continuous torque at n_{nom}	$M_{S1, n_{\text{nom}}}$	Nm	371
S1 continuous current at n_{nom}	$I_{S1, n_{\text{nom}}}$	A _{RMS}	90
S1 continuous power at n_{nom}	$P_{S1, n_{\text{nom}}}$	kW	58
S1 continuous efficiency at n_{nom}	$\eta_{S1, n_{\text{nom}}}$	%	93.66
S2 for 60s torque (maximum torque) ¹⁾	$M_{S2, 60 \text{ s}}$	Nm	711
S2 for 60s current (maximum current) ¹⁾	$I_{S2, 60 \text{ s}}$	A _{RMS}	195
S2 for 60s power (maximum power) ¹⁾	$P_{S2, 60 \text{ s}}$	kW	92
Maximum rotational speed	n_{max}	rpm	5500
S1 continuous torque at n_{max}	$M_{S1, n_{\text{max}}}$	Nm	44
S1 continuous current at n_{max}	$I_{S1, n_{\text{max}}}$	A _{RMS}	53
S1 continuous power at n_{max}	$P_{S1, \text{max}}$	kW	25
S1 continuous efficiency at n_{max}	$\eta_{S1, n_{\text{max}}}$	%	89.67
S1 continuous torque at $P_{S1, \text{max}}$	$M_{S1, P_{\text{max}}}$	Nm	264
S1 continuous current at $P_{S1, \text{max}}$	$I_{S1, P_{\text{max}}}$	A _{RMS}	88
S1 continuous power at $P_{S1, \text{max}}$	$P_{S1, P_{\text{max}}}$	kW	65
S1 continuous speed at $P_{S1, \text{max}}$	$n_{S1, P_{\text{max}}}$	%	2365
S1 continuous efficiency at $P_{S1, \text{max}}$	$\eta_{S1, P_{\text{max}}}$	%	94.10
Short circuit braking torque at nominal rotational speed ²⁾	$M_{\text{nom, sc}}$	Nm	18
Short circuit current at nominal speed ²⁾	$I_{\text{nom, sc}}$	A _{RMS}	103
Maximum short circuit braking torque ²⁾	$M_{\text{max, sc}}$	Nm	240
Maximum short circuit current ²⁾	$I_{\text{max, sc}}$	A _{RMS}	103
DC supply voltage	V_{DC}	V	700
Voltage for motor phases (outer conductor-outer conductor – RMS)	V_{LL}	V _{RMS}	475

Electric	Symbol	Unit	Value
Number of poles			8
Phase-phase voltage constant at 20 °C	k_{EMK}	V _{RMS} /1000 rpm	224.8
Torque constant at 25 °C	k_{T}	Nm/A _{RMS}	4.39
Synchronous inductance (d-axis) at rated current	L_{d}	mH	2.78
Synchronous inductance (q-axis) at rated current	L_{q}	mH	8.32
Stator winding resistance (phase) at 20 °C	R_{LL}	Ω	0.1792
Cogging torque (unskewed)	M_{cog}	Nm	12.06
Torque ripple	$M_{\text{Pk-Pk}}$	Nm	9.5

1) For the S2 calculation, the starting temperature of the components is assumed to be 25 °C.

2) Magnet temperature at 20 °C

▼ **Torque EMS1-16F15**

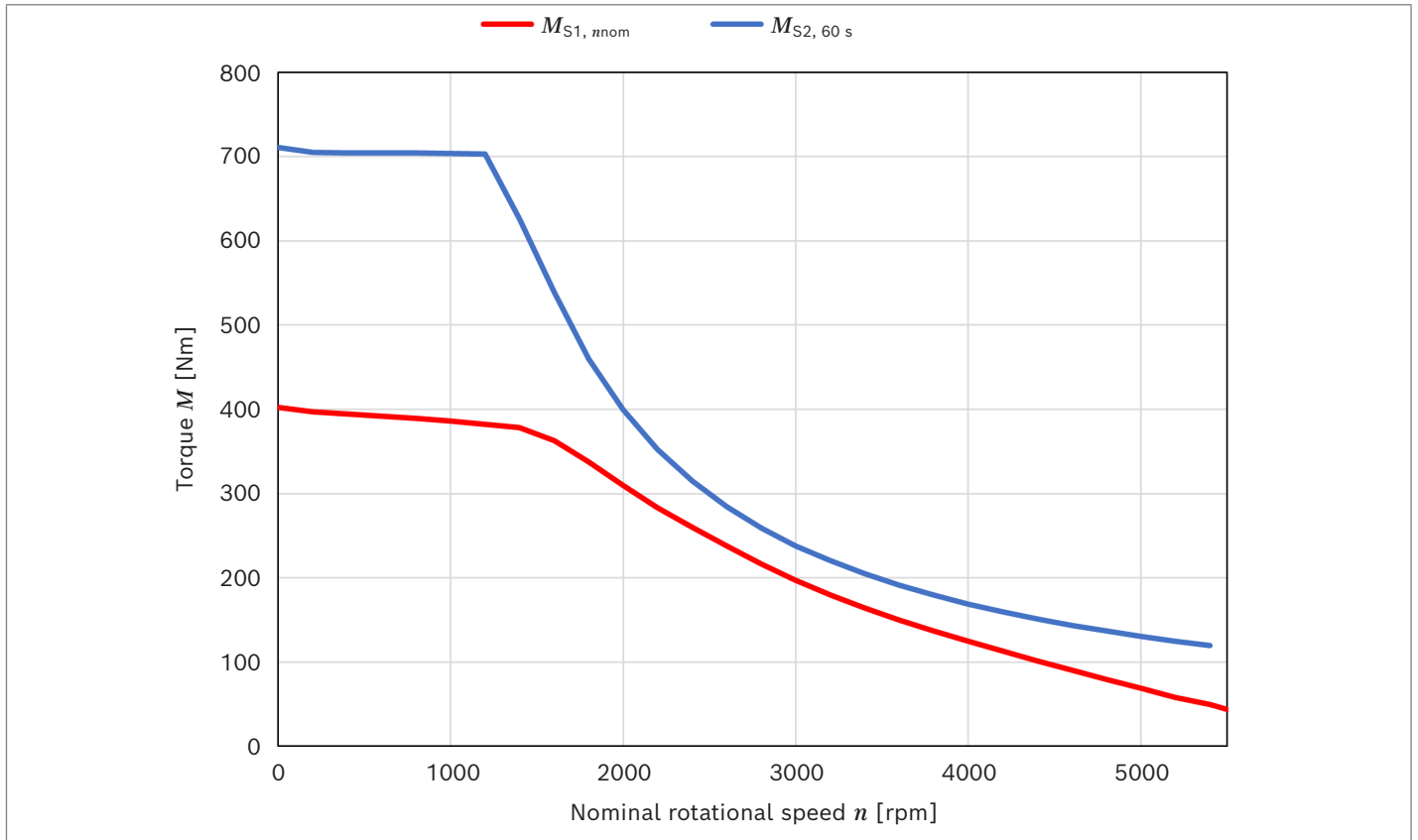

▼ **Power EMS1-16F15**

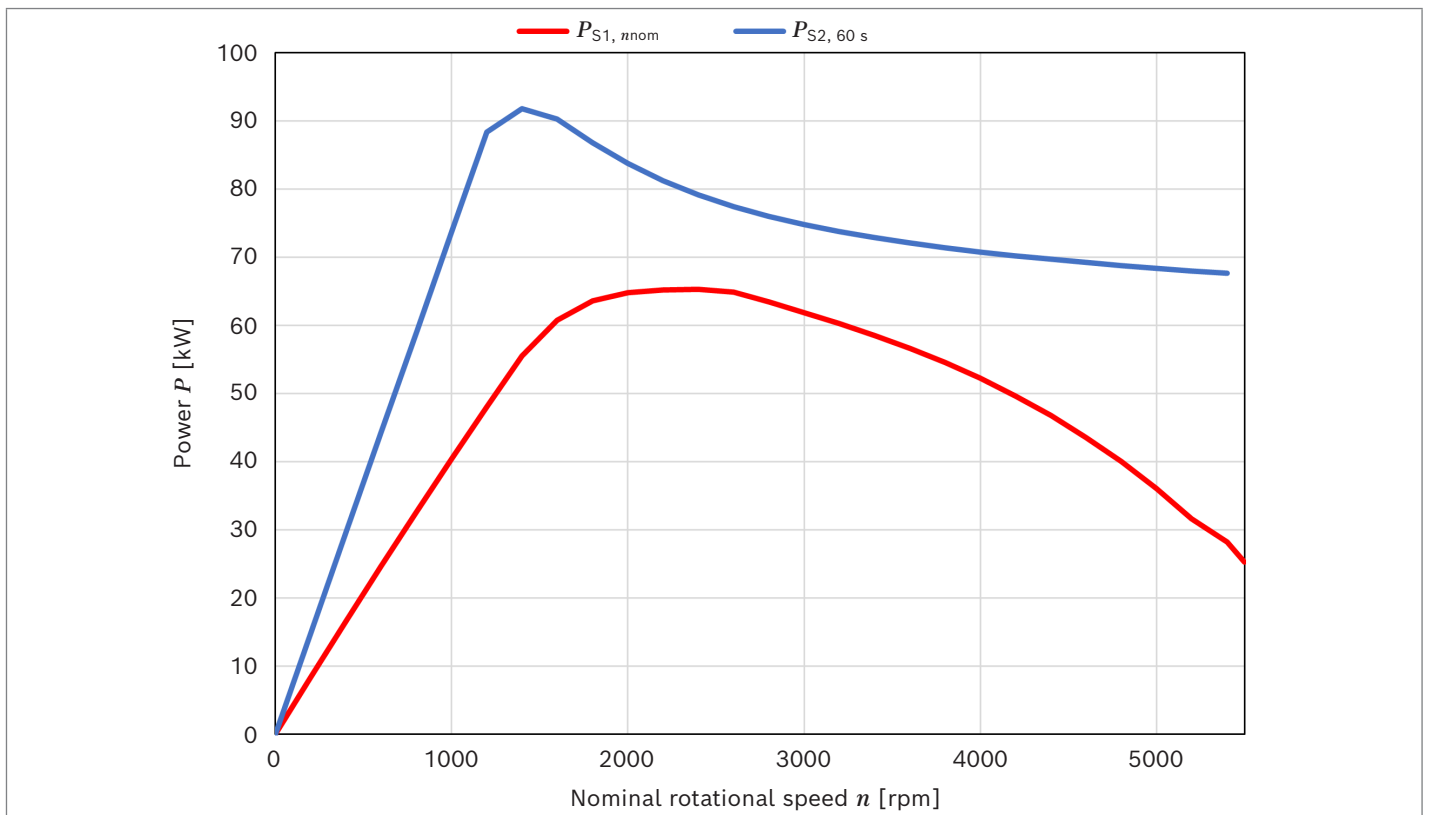

▼ **Short circuit current and short circuit braking torque EMS1-16F15**

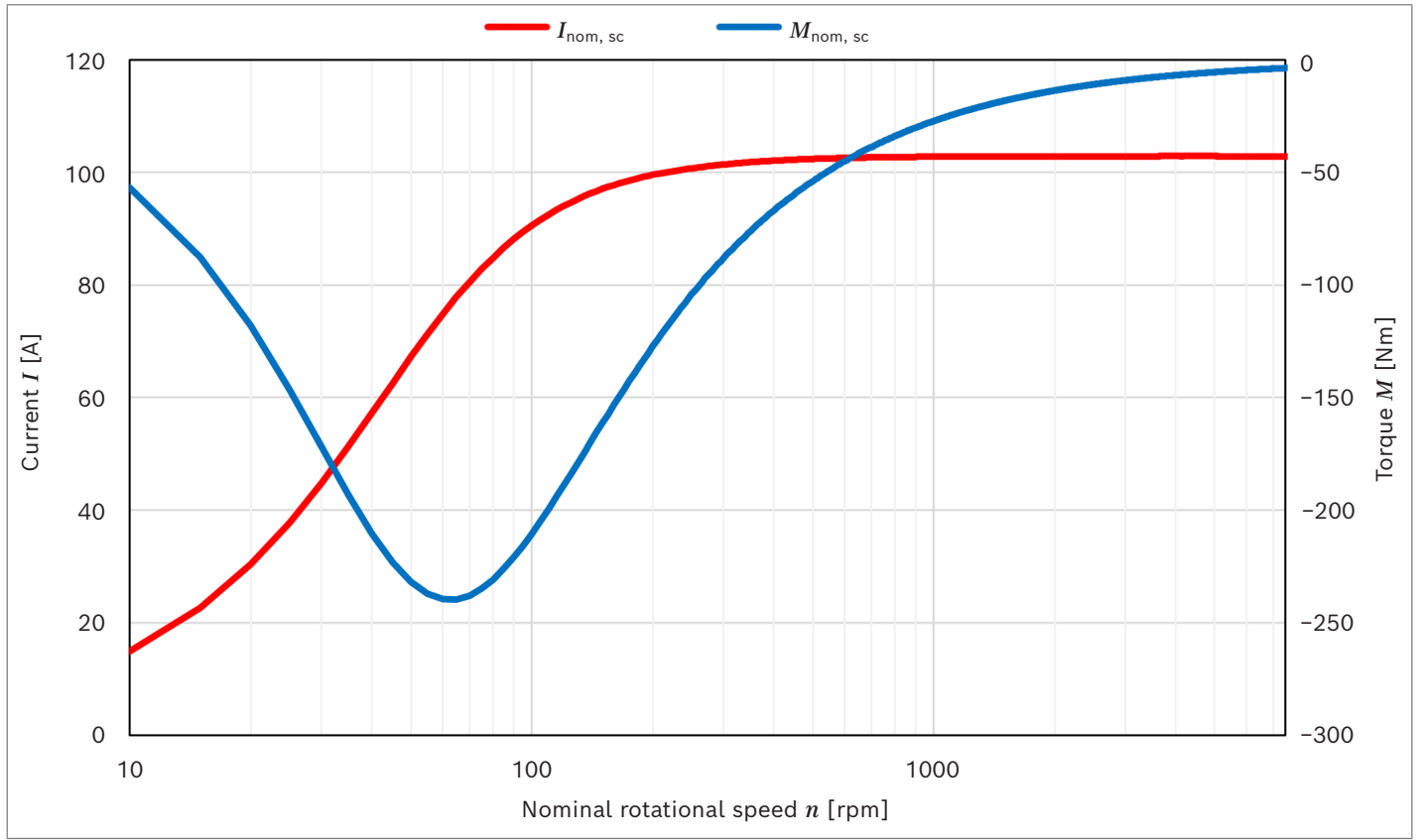

EMS1-16F20

Designation	Symbol	Unit	Value
S1 continuous torque at 200 rpm	$M_{S1, \text{low rotational speed}}$	Nm	401
S1 continuous current at 200 rpm	$I_{S1, \text{low rotational speed}}$	A _{RMS}	123
Nominal rotational speed	n_{nom}	rpm	2000
S1 continuous torque at n_{nom}	$M_{S1, n_{\text{nom}}}$	Nm	366
S1 continuous current at n_{nom}	$I_{S1, n_{\text{nom}}}$	A _{RMS}	117
S1 continuous power at n_{nom}	$P_{S1, n_{\text{nom}}}$	kW	77
S1 continuous efficiency at n_{nom}	$\eta_{S1, n_{\text{nom}}}$	%	94.73
S2 for 60s torque (maximum torque) ¹⁾	$M_{S2, 60 \text{ s}}$	Nm	711
S2 for 60s current (maximum current) ¹⁾	$I_{S2, 60 \text{ s}}$	A _{RMS}	254
S2 for 60s power (maximum power) ¹⁾	$P_{S2, 60 \text{ s}}$	kW	122
Maximum rotational speed	n_{max}	rpm	5500
S1 continuous torque at n_{max}	$M_{S1, n_{\text{max}}}$	Nm	73
S1 continuous current at n_{max}	$I_{S1, n_{\text{max}}}$	A _{RMS}	67
S1 continuous power at n_{max}	$P_{S1, \text{max}}$	kW	42
S1 continuous efficiency at n_{max}	$\eta_{S1, n_{\text{max}}}$	%	93.44
S1 continuous torque at $P_{S1, \text{max}}$	$M_{S1, P_{\text{max}}}$	Nm	308
S1 continuous current at $P_{S1, \text{max}}$	$I_{S1, P_{\text{max}}}$	A _{RMS}	114
S1 continuous power at $P_{S1, \text{max}}$	$P_{S1, P_{\text{max}}}$	kW	83
S1 continuous speed at $P_{S1, \text{max}}$	$n_{S1, P_{\text{max}}}$	%	2585
S1 continuous efficiency at $P_{S1, \text{max}}$	$\eta_{S1, P_{\text{max}}}$	%	95.12
Short circuit braking torque at nominal rotational speed ²⁾	$M_{\text{nom, sc}}$	Nm	14
Short circuit current at nominal speed ²⁾	$I_{\text{nom, sc}}$	A _{RMS}	134
Maximum short circuit braking torque ²⁾	$M_{\text{max, sc}}$	Nm	240
Maximum short circuit current ²⁾	$I_{\text{max, sc}}$	A _{RMS}	134
DC supply voltage	V_{DC}	V	700
Voltage for motor phases (outer conductor-outer conductor – RMS)	V_{LL}	V _{RMS}	475

Electric	Symbol	Unit	Value
Number of poles			8
Phase-phase voltage constant at 20 °C	k_{EMK}	V _{RMS} / 1000 rpm	171.9
Torque constant at 25 °C	k_{T}	Nm / A _{RMS}	3.36
Synchronous inductance (d-axis) at rated current	L_{d}	mH	1.63
Synchronous inductance (q-axis) at rated current	L_{q}	mH	4.88
Stator winding resistance (phase) at 20 °C	R_{LL}	Ω	0.1
Cogging torque (unskewed)	M_{cog}	Nm	12.06
Torque ripple	$M_{\text{Pk-Pk}}$	Nm	9.43

1) For the S2 calculation, the starting temperature of the components is assumed to be 25 °C.

2) Magnet temperature at 20 °C

▼ **Torque EMS1-16F20**

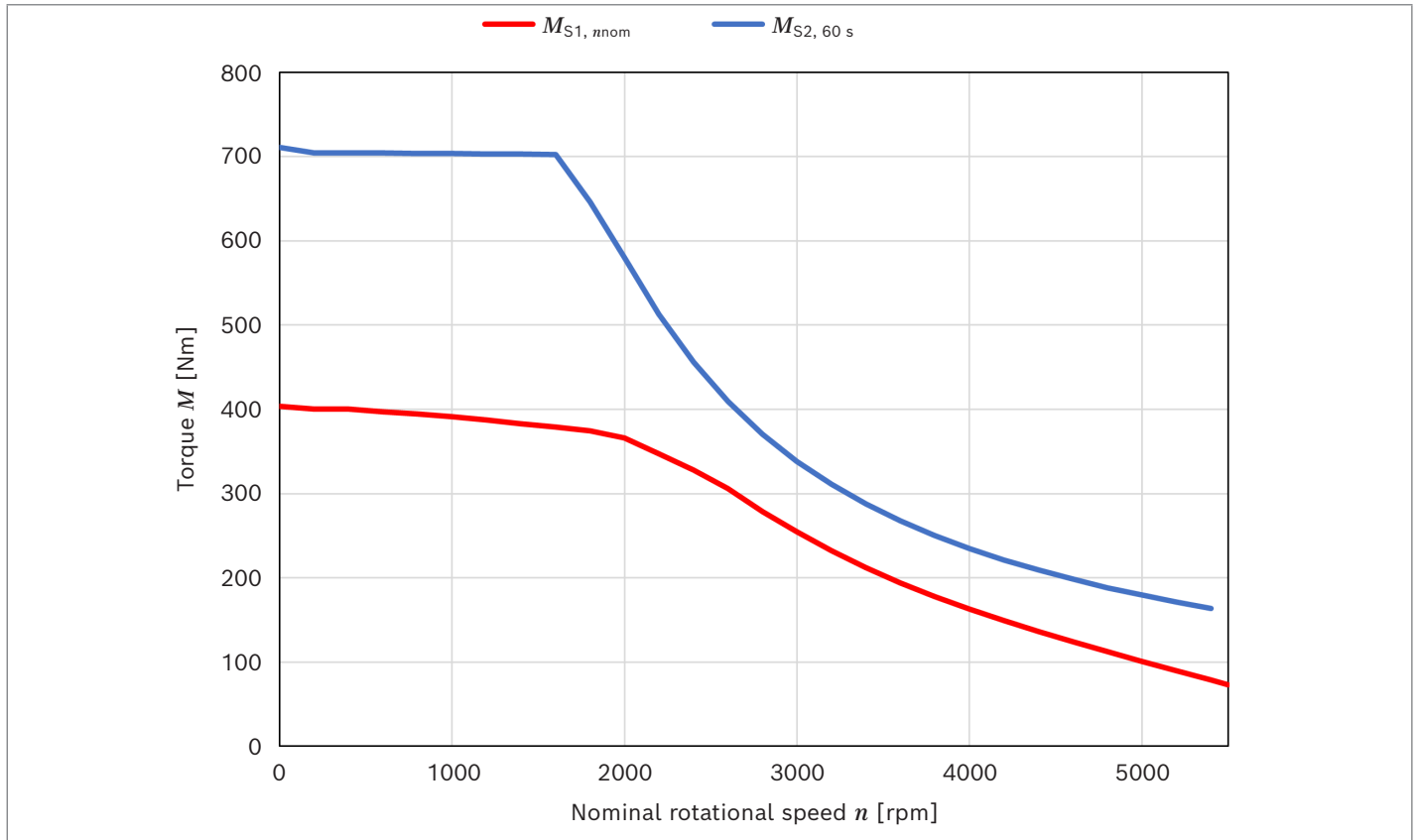

▼ **Power EMS1-16F20**

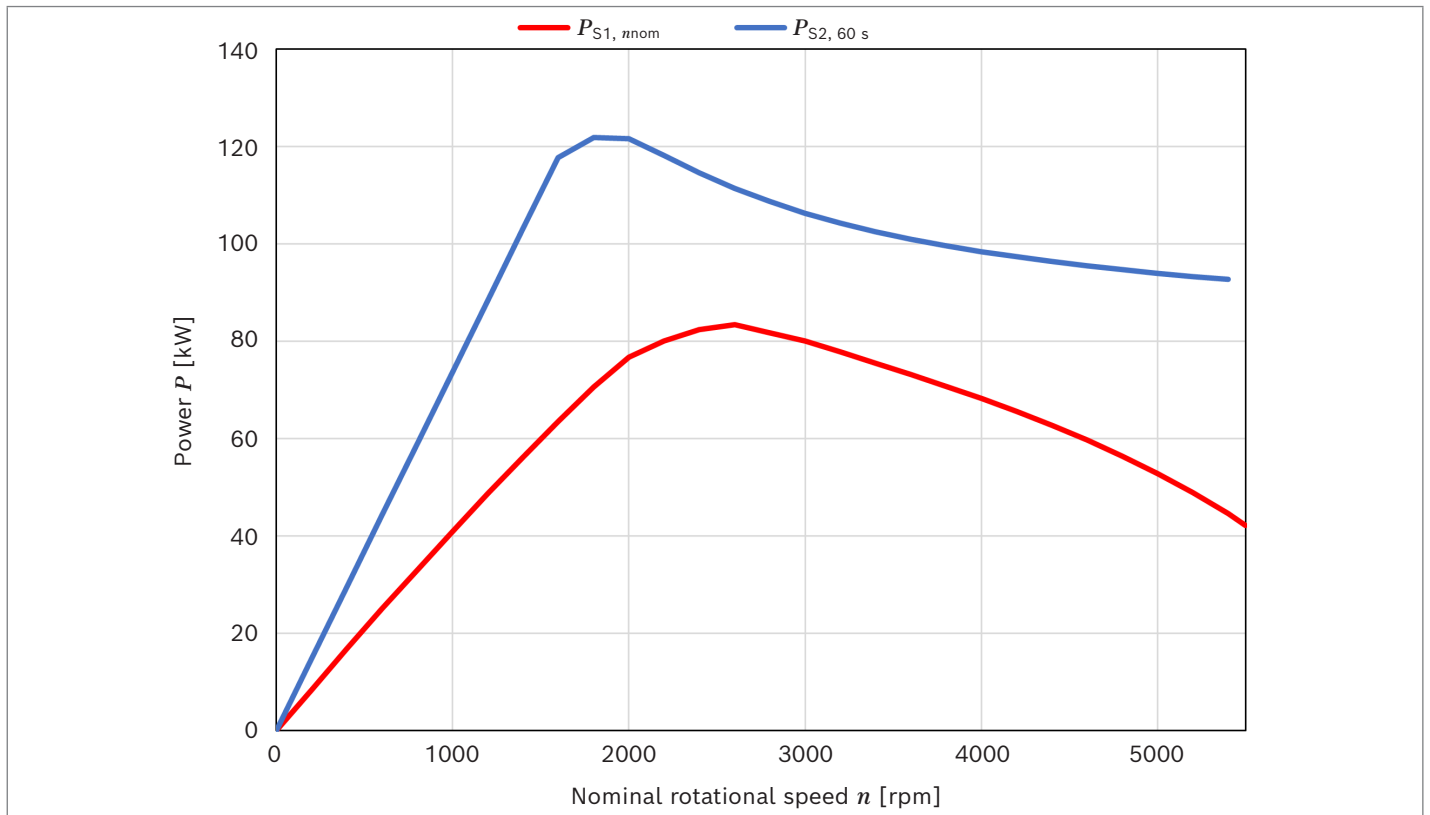

▼ Short circuit current and short circuit braking torque EMS1-16F20

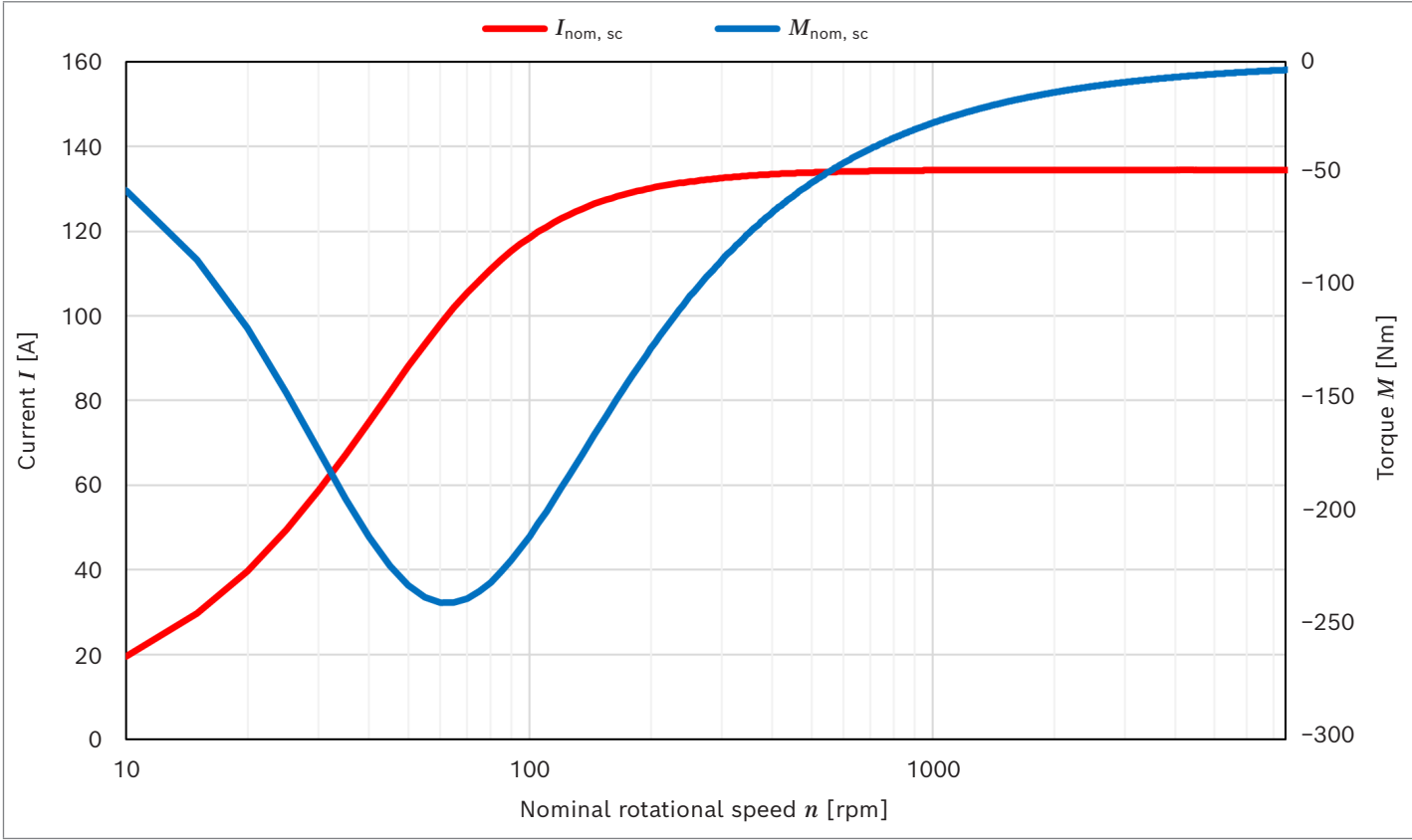

EMS1-16F25

Designation	Symbol	Unit	Value
S1 continuous torque at 200 rpm	$M_{S1, \text{low rotational speed}}$	Nm	399
S1 continuous current at 200 rpm	$I_{S1, \text{low rotational speed}}$	A _{RMS}	145
Nominal rotational speed	n_{nom}	rpm	2500
S1 continuous torque at n_{nom}	$M_{S1, n_{\text{nom}}}$	Nm	346
S1 continuous current at n_{nom}	$I_{S1, n_{\text{nom}}}$	A _{RMS}	133
S1 continuous power at n_{nom}	$P_{S1, n_{\text{nom}}}$	kW	90
S1 continuous efficiency at n_{nom}	$\eta_{S1, n_{\text{nom}}}$	%	95.27
S2 for 60s torque (maximum torque) ¹⁾	$M_{S2, 60 \text{ s}}$	Nm	711
S2 for 60s current (maximum current) ¹⁾	$I_{S2, 60 \text{ s}}$	A _{RMS}	301
S2 for 60s power (maximum power) ¹⁾	$P_{S2, 60 \text{ s}}$	kW	145
Maximum rotational speed	n_{max}	rpm	5500
S1 continuous torque at n_{max}	$M_{S1, n_{\text{max}}}$	Nm	96
S1 continuous current at n_{max}	$I_{S1, n_{\text{max}}}$	A _{RMS}	78
S1 continuous power at n_{max}	$P_{S1, \text{max}}$	kW	55
S1 continuous efficiency at n_{max}	$\eta_{S1, n_{\text{max}}}$	%	94.74
S1 continuous torque at $P_{S1, \text{max}}$	$M_{S1, P_{\text{max}}}$	Nm	317
S1 continuous current at $P_{S1, \text{max}}$	$I_{S1, P_{\text{max}}}$	A _{RMS}	129
S1 continuous power at $P_{S1, \text{max}}$	$P_{S1, P_{\text{max}}}$	kW	93
S1 continuous speed at $P_{S1, \text{max}}$	$n_{S1, P_{\text{max}}}$	%	2805
S1 continuous efficiency at $P_{S1, \text{max}}$	$\eta_{S1, P_{\text{max}}}$	%	95.57
Short circuit braking torque at nominal rotational speed ²⁾	$M_{\text{nom, sc}}$	Nm	11
Short circuit current at nominal speed ²⁾	$I_{\text{nom, sc}}$	A _{RMS}	159
Maximum short circuit braking torque ²⁾	$M_{\text{max, sc}}$	Nm	240
Maximum short circuit current ²⁾	$I_{\text{max, sc}}$	A _{RMS}	159
DC supply voltage	V_{DC}	V	700
Voltage for motor phases (outer conductor-outer conductor – RMS)	V_{LL}	V _{RMS}	475

Electric	Symbol	Unit	Value
Number of poles			8
Phase-phase voltage constant at 20 °C	k_{EMK}	V _{RMS} /1000 rpm	145.5
Torque constant at 25 °C	k_{T}	Nm/A _{RMS}	2.85
Synchronous inductance (d-axis) at rated current	L_{d}	mH	1.17
Synchronous inductance (q-axis) at rated current	L_{q}	mH	3.54
Stator winding resistance (phase) at 20 °C	R_{LL}	Ω	0.072
Cogging torque (unskewed)	M_{cog}	Nm	12.06
Torque ripple	$M_{\text{Pk-Pk}}$	Nm	9.36

1) For the S2 calculation, the starting temperature of the components is assumed to be 25 °C.

2) Magnet temperature at 20 °C

▼ Torque EMS1-16F25

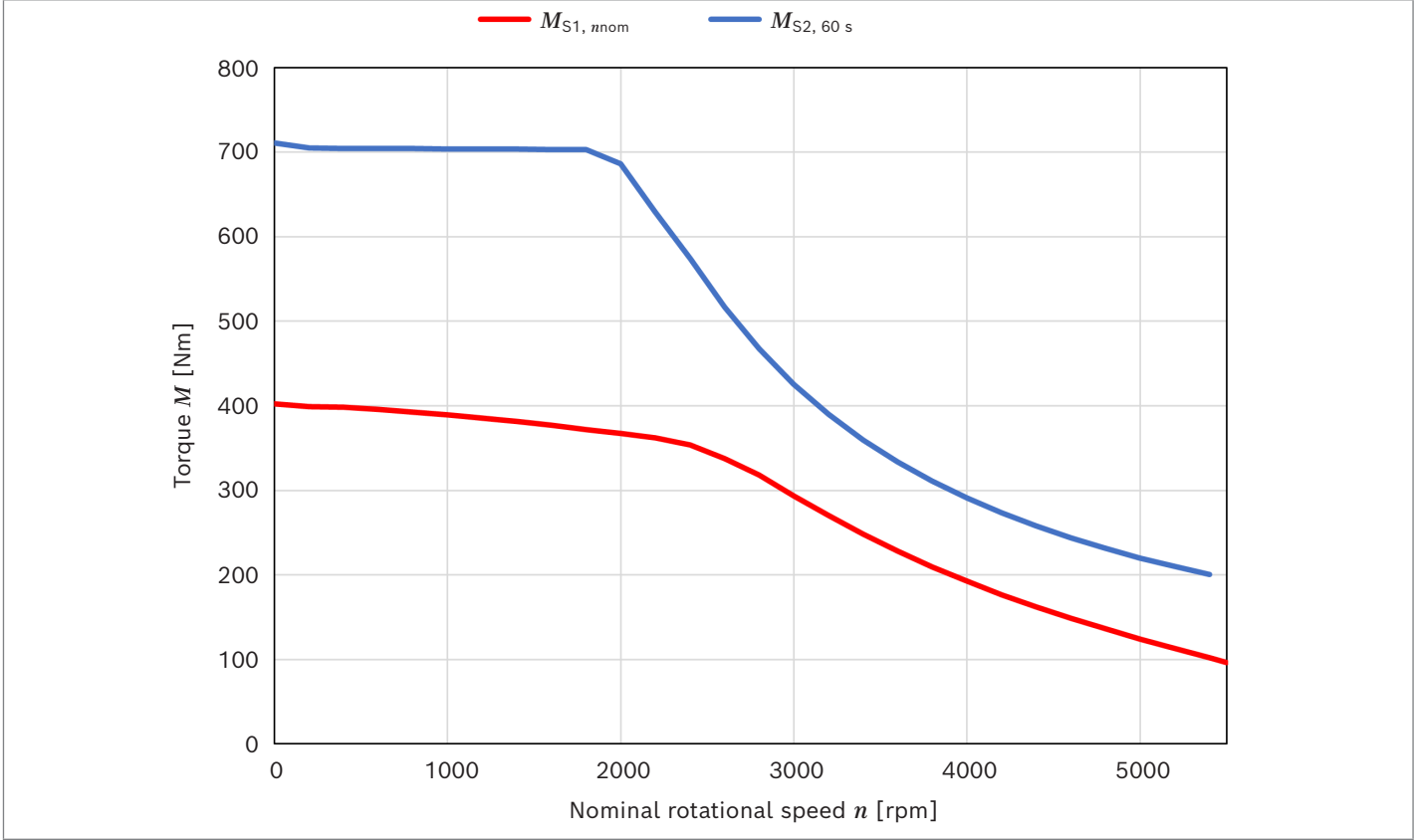

▼ Power EMS1-16F25

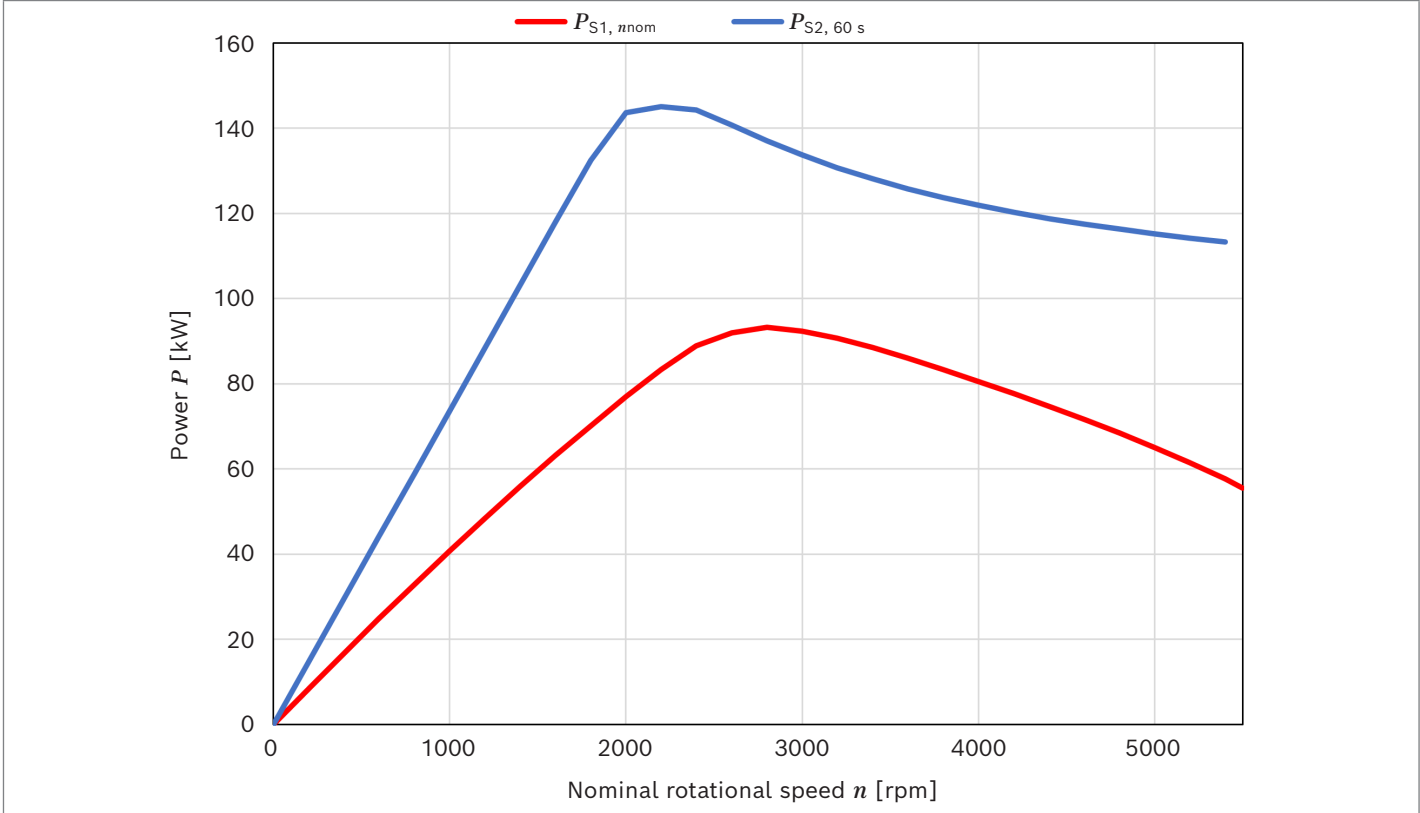

▼ **Short circuit current and short circuit braking torque EMS1-16F25**

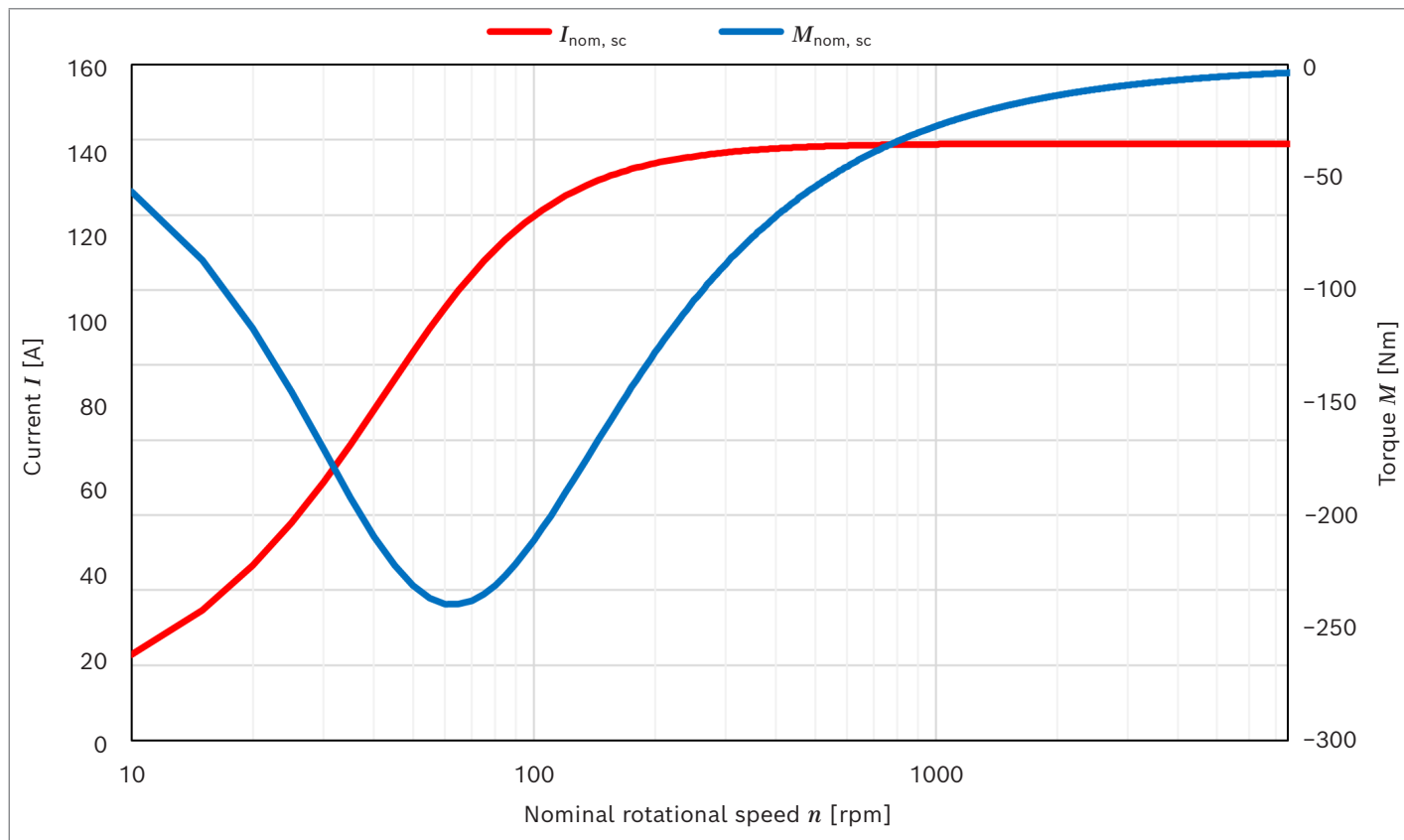

EMS1-16H10

Designation	Symbol	Unit	Value
S1 continuous torque at 200 rpm	$M_{S1, \text{low rotational speed}}$	Nm	524
S1 continuous current at 200 rpm	$I_{S1, \text{low rotational speed}}$	A _{RMS}	79
Nominal rotational speed	n_{nom}	rpm	1000
S1 continuous torque at n_{nom}	$M_{S1, n_{\text{nom}}}$	Nm	490
S1 continuous current at n_{nom}	$I_{S1, n_{\text{nom}}}$	A _{RMS}	77
S1 continuous power at n_{nom}	$P_{S1, n_{\text{nom}}}$	kW	51
S1 continuous efficiency at n_{nom}	$\eta_{S1, n_{\text{nom}}}$	%	92.21
S2 for 60s torque (maximum torque) ¹⁾	$M_{S2, 60 \text{ s}}$	Nm	948
S2 for 60s current (maximum current) ¹⁾	$I_{S2, 60 \text{ s}}$	A _{RMS}	165
S2 for 60s power (maximum power) ¹⁾	$P_{S2, 60 \text{ s}}$	kW	77
Maximum rotational speed	n_{max}	rpm	5500
S1 continuous torque at n_{max}	$M_{S1, n_{\text{max}}}$	Nm	0
S1 continuous current at n_{max}	$I_{S1, n_{\text{max}}}$	A _{RMS}	0
S1 continuous power at n_{max}	$P_{S1, n_{\text{max}}}$	kW	0
S1 continuous efficiency at n_{max}	$\eta_{S1, n_{\text{max}}}$	%	0.00
S1 continuous torque at $P_{S1, \text{max}}$	$M_{S1, P_{\text{max}}}$	Nm	324
S1 continuous current at $P_{S1, \text{max}}$	$I_{S1, P_{\text{max}}}$	A _{RMS}	76
S1 continuous power at $P_{S1, \text{max}}$	$P_{S1, P_{\text{max}}}$	kW	56
S1 continuous speed at $P_{S1, \text{max}}$	$n_{S1, P_{\text{max}}}$	%	1650
S1 continuous efficiency at $P_{S1, \text{max}}$	$\eta_{S1, P_{\text{max}}}$	%	92.61
Short circuit braking torque at nominal rotational speed ²⁾	$M_{\text{nom, sc}}$	Nm	33
Short circuit current at nominal speed ²⁾	$I_{\text{nom, sc}}$	A _{RMS}	88
Maximum short circuit braking torque ²⁾	$M_{\text{max, sc}}$	Nm	322
Maximum short circuit current ²⁾	$I_{\text{max, sc}}$	A _{RMS}	88
DC supply voltage	V_{DC}	V	700
Voltage for motor phases (outer conductor-outer conductor – RMS)	V_{LL}	V _{RMS}	475

Electric	Symbol	Unit	Value
Number of poles			8
Phase-phase voltage constant at 20 °C	k_{EMK}	V _{RMS} / 1000 rpm	352.6
Torque constant at 25 °C	k_{T}	Nm / A _{RMS}	6.88
Synchronous inductance (d-axis) at rated current	L_{d}	mH	5.21
Synchronous inductance (q-axis) at rated current	L_{q}	mH	15
Stator winding resistance (phase) at 20 °C	R_{LL}	Ω	0.281
Cogging torque (unskewed)	M_{cog}	Nm	16.08
Torque ripple	$M_{\text{Pk-Pk}}$	Nm	11.76

1) For the S2 calculation, the starting temperature of the components is assumed to be 25 °C.

2) Magnet temperature at 20 °C

▼ **Torque EMS1-16H10**

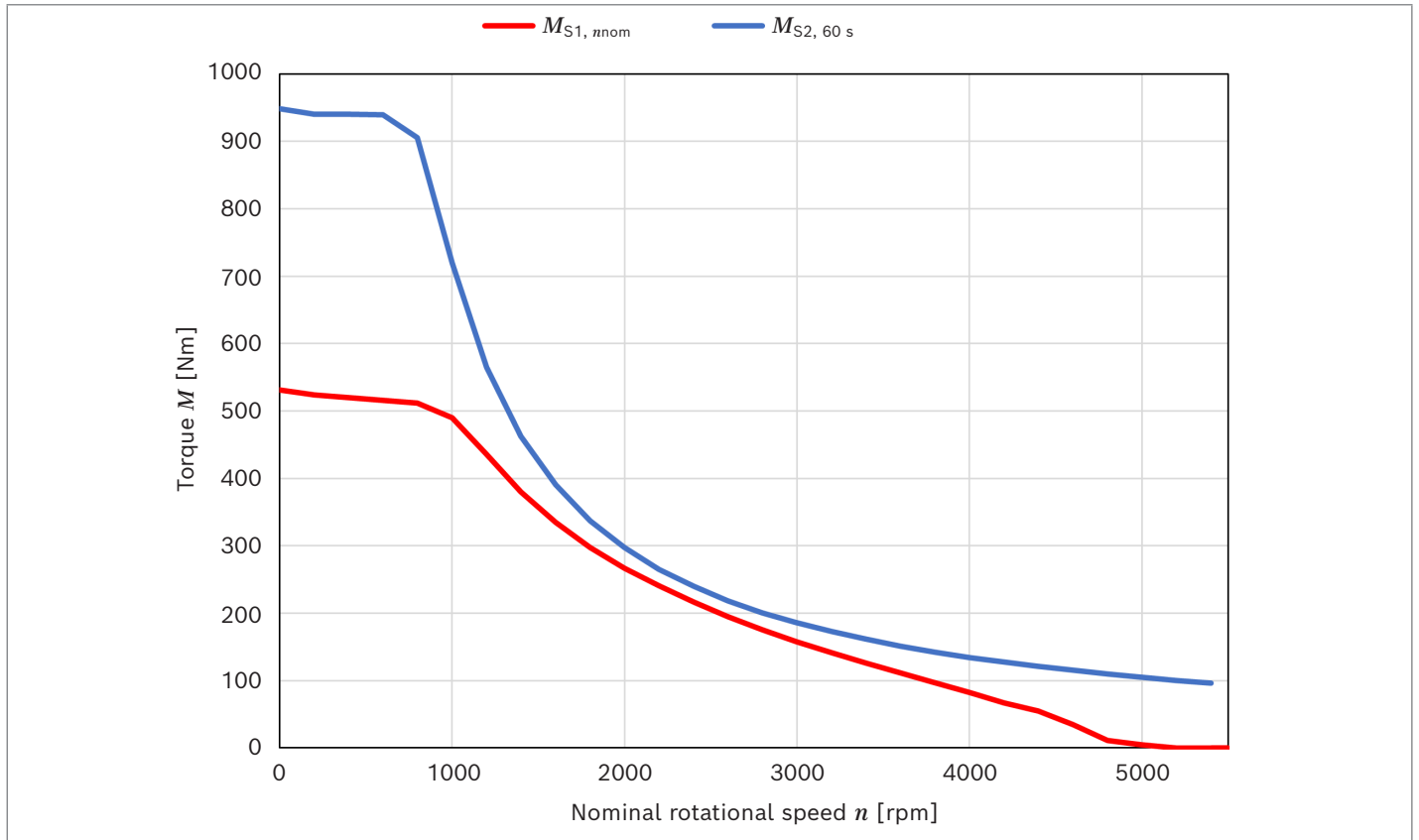

▼ **Power EMS1-16H10**

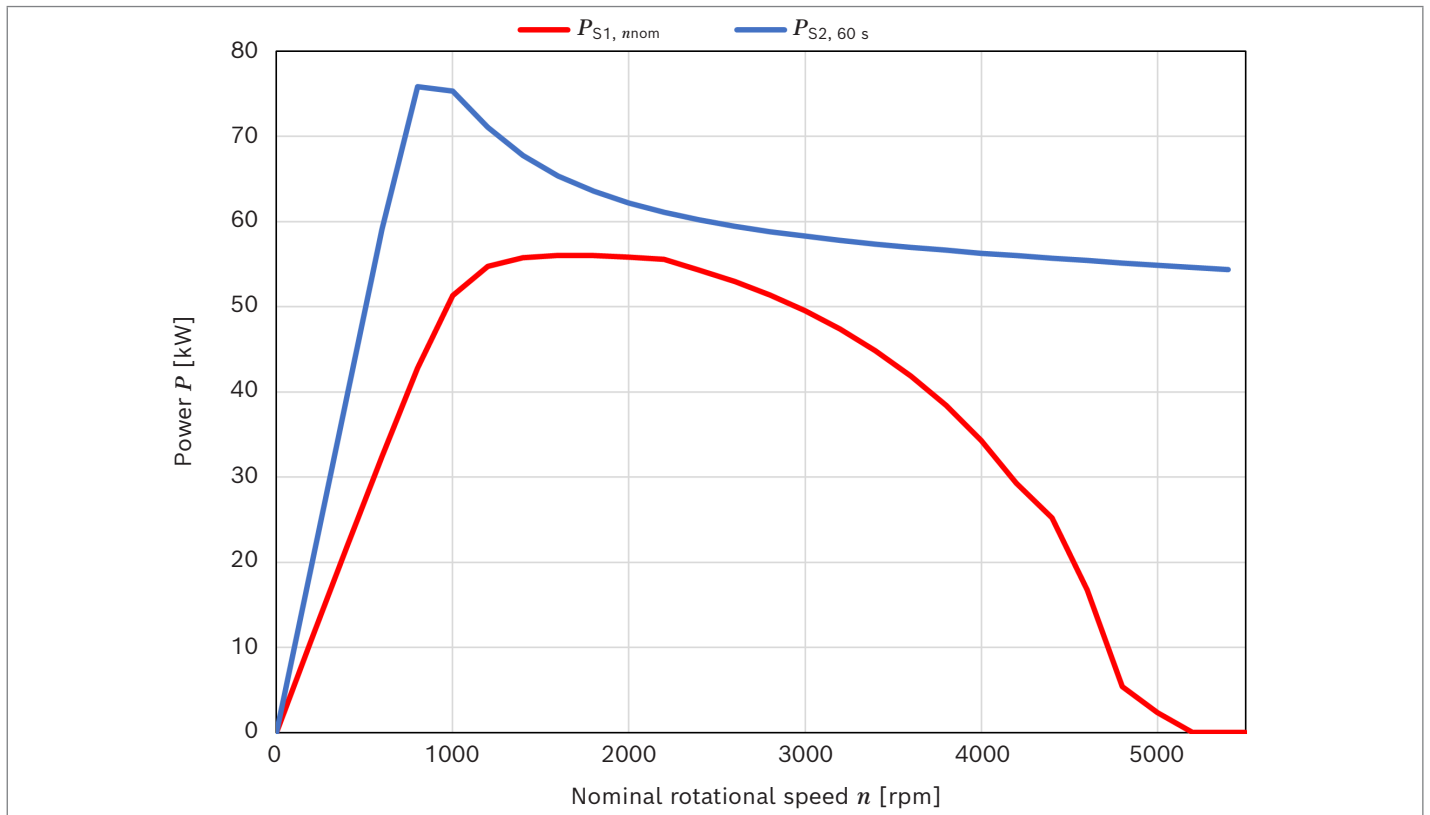

▼ Short circuit current and short circuit braking torque EMS1-16H10

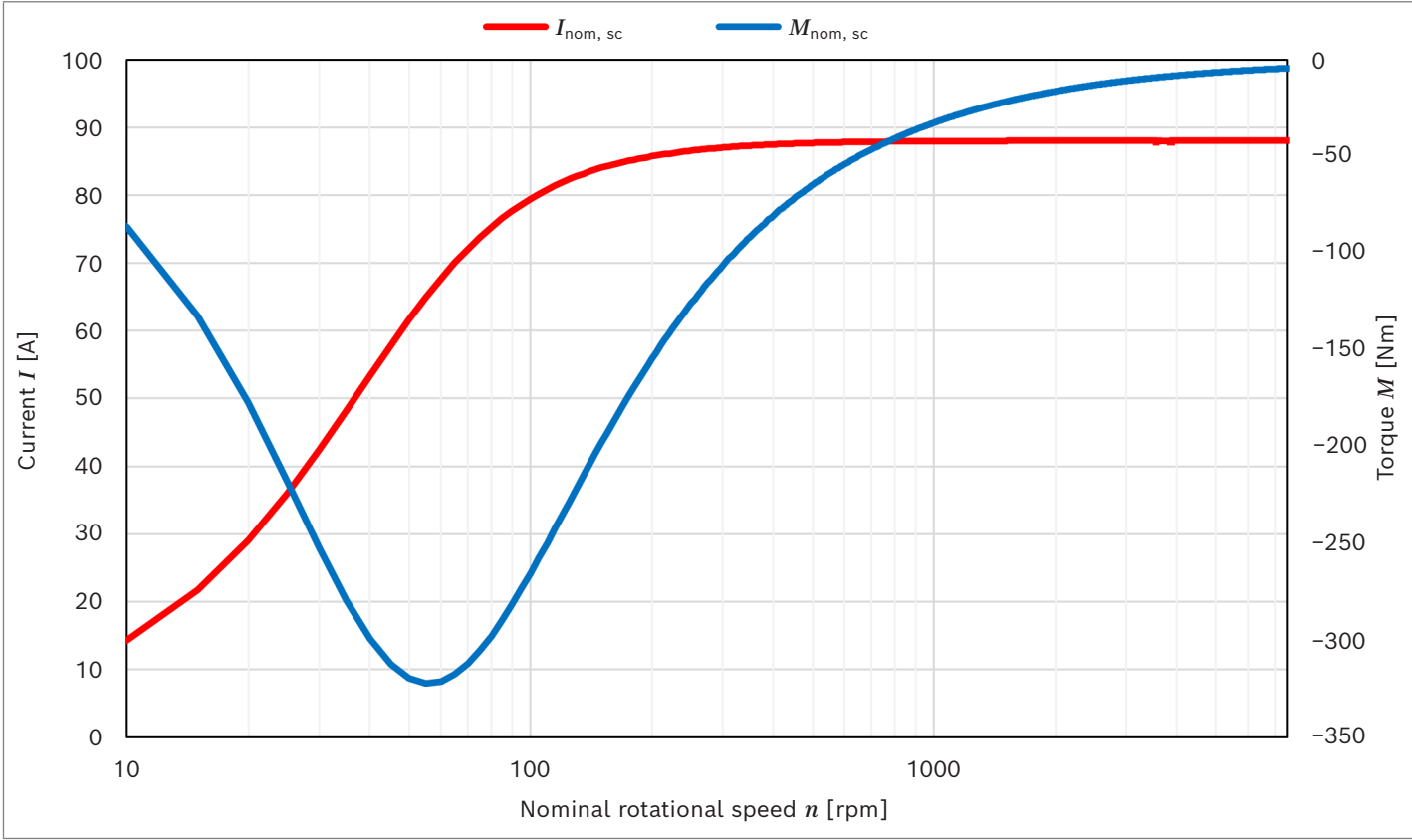

EMS1-16H15

Designation	Symbol	Unit	Value
S1 continuous torque at 200 rpm	$M_{S1, \text{low rotational speed}}$	Nm	524
S1 continuous current at 200 rpm	$I_{S1, \text{low rotational speed}}$	A _{RMS}	121
Nominal rotational speed	n_{nom}	rpm	1500
S1 continuous torque at n_{nom}	$M_{S1, n_{\text{nom}}}$	Nm	483
S1 continuous current at n_{nom}	$I_{S1, n_{\text{nom}}}$	A _{RMS}	116
S1 continuous power at n_{nom}	$P_{S1, n_{\text{nom}}}$	kW	76
S1 continuous efficiency at n_{nom}	$\eta_{S1, n_{\text{nom}}}$	%	94.20
S2 for 60s torque (maximum torque) ¹⁾	$M_{S2, 60 \text{ s}}$	Nm	948
S2 for 60s current (maximum current) ¹⁾	$I_{S2, 60 \text{ s}}$	A _{RMS}	254
S2 for 60s power (maximum power) ¹⁾	$P_{S2, 60 \text{ s}}$	kW	122
Maximum rotational speed	n_{max}	rpm	5500
S1 continuous torque at n_{max}	$M_{S1, n_{\text{max}}}$	Nm	12
S1 continuous current at n_{max}	$I_{S1, n_{\text{max}}}$	A _{RMS}	63
S1 continuous power at n_{max}	$P_{S1, \text{max}}$	kW	7
S1 continuous efficiency at n_{max}	$\eta_{S1, n_{\text{max}}}$	%	22.44
S1 continuous torque at $P_{S1, \text{max}}$	$M_{S1, P_{\text{max}}}$	Nm	374
S1 continuous current at $P_{S1, \text{max}}$	$I_{S1, P_{\text{max}}}$	A _{RMS}	113
S1 continuous power at $P_{S1, \text{max}}$	$P_{S1, P_{\text{max}}}$	kW	84
S1 continuous speed at $P_{S1, \text{max}}$	$n_{S1, P_{\text{max}}}$	%	2145
S1 continuous efficiency at $P_{S1, \text{max}}$	$\eta_{S1, P_{\text{max}}}$	%	94.72
Short circuit braking torque at nominal rotational speed ²⁾	$M_{\text{nom, sc}}$	Nm	22
Short circuit current at nominal speed ²⁾	$I_{\text{nom, sc}}$	A _{RMS}	135
Maximum short circuit braking torque ²⁾	$M_{\text{max, sc}}$	Nm	322
Maximum short circuit current ²⁾	$I_{\text{max, sc}}$	A _{RMS}	135
DC supply voltage	V_{DC}	V	700
Voltage for motor phases (outer conductor-outer conductor – RMS)	V_{LL}	V _{RMS}	475

Electric	Symbol	Unit	Value
Number of poles			8
Phase-phase voltage constant at 20 °C	k_{EMK}	V _{RMS} /1000 rpm	229.2
Torque constant at 25 °C	k_{T}	Nm/A _{RMS}	4.48
Synchronous inductance (d-axis) at rated current	L_{d}	mH	2.16
Synchronous inductance (q-axis) at rated current	L_{q}	mH	5.01
Stator winding resistance (phase) at 20 °C	R_{LL}	Ω	0.124
Cogging torque (unskewed)	M_{cog}	Nm	16.08
Torque ripple	$M_{\text{Pk-Pk}}$	Nm	12.45

1) For the S2 calculation, the starting temperature of the components is assumed to be 25 °C.

2) Magnet temperature at 20 °C

▼ Torque EMS1-16H15

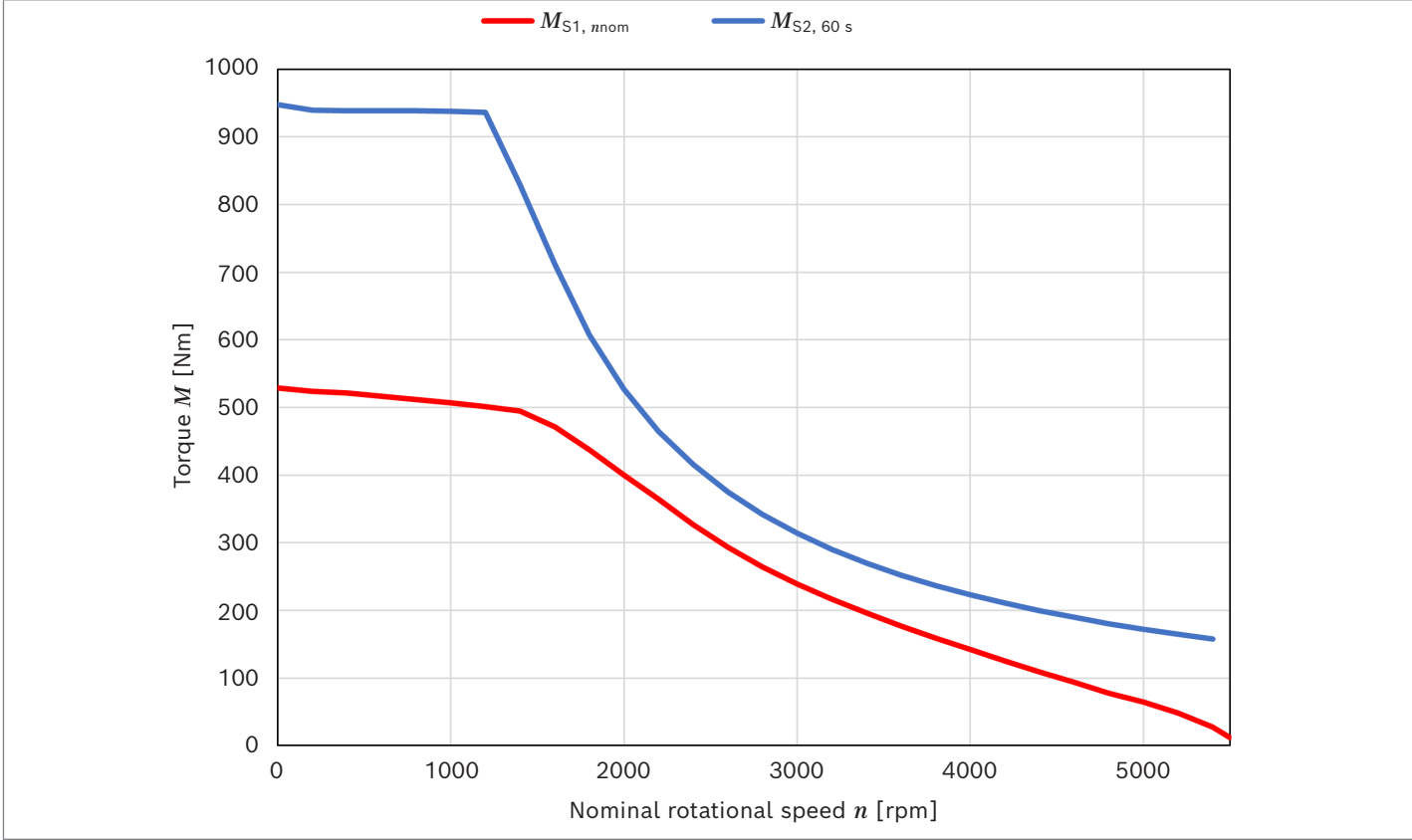

▼ Power EMS1-16H15

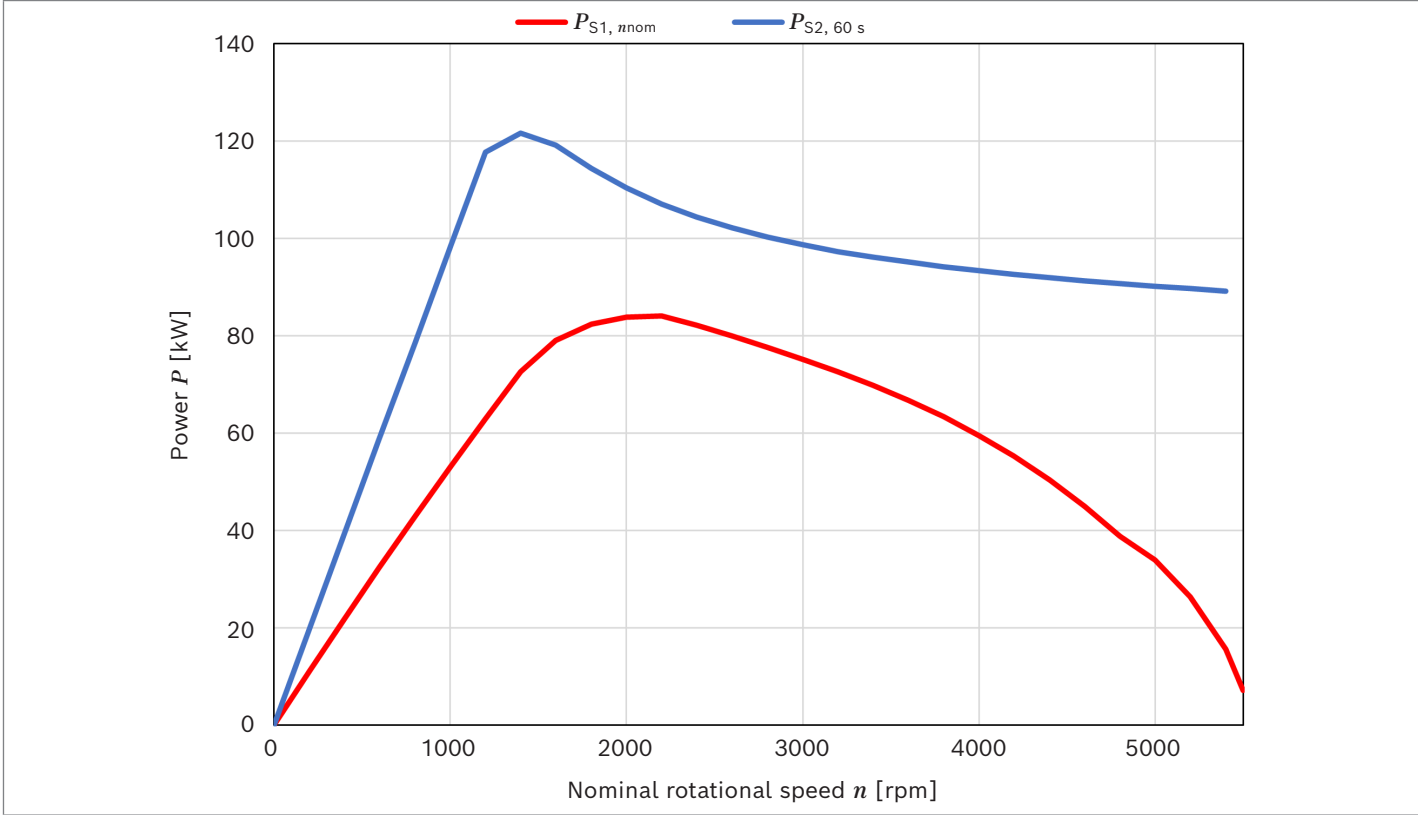

▼ **Short circuit current and short circuit braking torque EMS1-16H15**

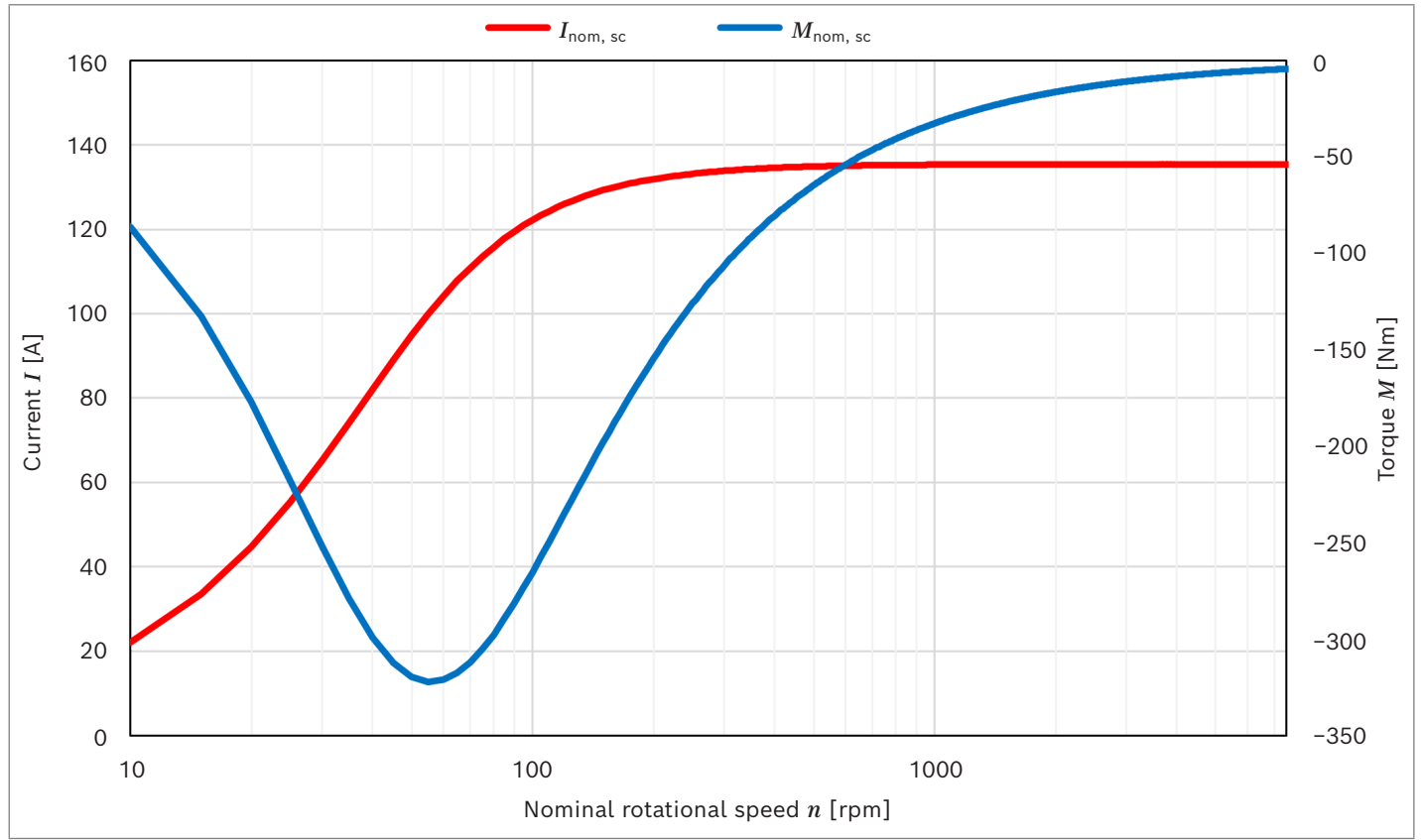

EMS1-16H20

Designation	Symbol	Unit	Value
S1 continuous torque at 200 rpm	$M_{S1, \text{low rotational speed}}$	Nm	525
S1 continuous current at 200 rpm	$I_{S1, \text{low rotational speed}}$	A _{RMS}	157
Nominal rotational speed	n_{nom}	rpm	2000
S1 continuous torque at n_{nom}	$M_{S1, n_{\text{nom}}}$	Nm	467
S1 continuous current at n_{nom}	$I_{S1, n_{\text{nom}}}$	A _{RMS}	146
S1 continuous power at n_{nom}	$P_{S1, n_{\text{nom}}}$	kW	98
S1 continuous efficiency at n_{nom}	$\eta_{S1, n_{\text{nom}}}$	%	95.22
S2 for 60s torque (maximum torque) ¹⁾	$M_{S2, 60 \text{ s}}$	Nm	948
S2 for 60s current (maximum current) ¹⁾	$I_{S2, 60 \text{ s}}$	A _{RMS}	331
S2 for 60s power (maximum power) ¹⁾	$P_{S2, 60 \text{ s}}$	kW	160
Maximum rotational speed	n_{max}	rpm	5500
S1 continuous torque at n_{max}	$M_{S1, n_{\text{max}}}$	Nm	73
S1 continuous current at n_{max}	$I_{S1, n_{\text{max}}}$	A _{RMS}	80
S1 continuous power at n_{max}	$P_{S1, n_{\text{max}}}$	kW	42
S1 continuous efficiency at n_{max}	$\eta_{S1, n_{\text{max}}}$	%	92.30
S1 continuous torque at $P_{S1, \text{max}}$	$M_{S1, P_{\text{max}}}$	Nm	411
S1 continuous current at $P_{S1, \text{max}}$	$I_{S1, P_{\text{max}}}$	A _{RMS}	143
S1 continuous power at $P_{S1, \text{max}}$	$P_{S1, P_{\text{max}}}$	kW	104
S1 continuous speed at $P_{S1, \text{max}}$	$n_{S1, P_{\text{max}}}$	%	2420
S1 continuous efficiency at $P_{S1, \text{max}}$	$\eta_{S1, P_{\text{max}}}$	%	95.44
Short circuit braking torque at nominal rotational speed ²⁾	$M_{\text{nom, sc}}$	Nm	16
Short circuit current at nominal speed ²⁾	$I_{\text{nom, sc}}$	A _{RMS}	176
Maximum short circuit braking torque ²⁾	$M_{\text{max, sc}}$	Nm	322
Maximum short circuit current ²⁾	$I_{\text{max, sc}}$	A _{RMS}	176
DC supply voltage	V_{DC}	V	700
Voltage for motor phases (outer conductor-outer conductor – RMS)	V_{LL}	V _{RMS}	475

Electric	Symbol	Unit	Value
Number of poles			8
Phase-phase voltage constant at 20 °C	k_{EMK}	V _{RMS} / 1000 rpm	176.3
Torque constant at 25 °C	k_{T}	Nm / A _{RMS}	3.45
Synchronous inductance (d-axis) at rated current	L_{d}	mH	1.28
Synchronous inductance (q-axis) at rated current	L_{q}	mH	3.9
Stator winding resistance (phase) at 20 °C	R_{LL}	Ω	0.071
Cogging torque (unskewed)	M_{cog}	Nm	16.08
Torque ripple	$M_{\text{Pk-Pk}}$	Nm	12.11

1) For the S2 calculation, the starting temperature of the components is assumed to be 25 °C.

2) Magnet temperature at 20 °C

▼ **Torque EMS1-16H20**

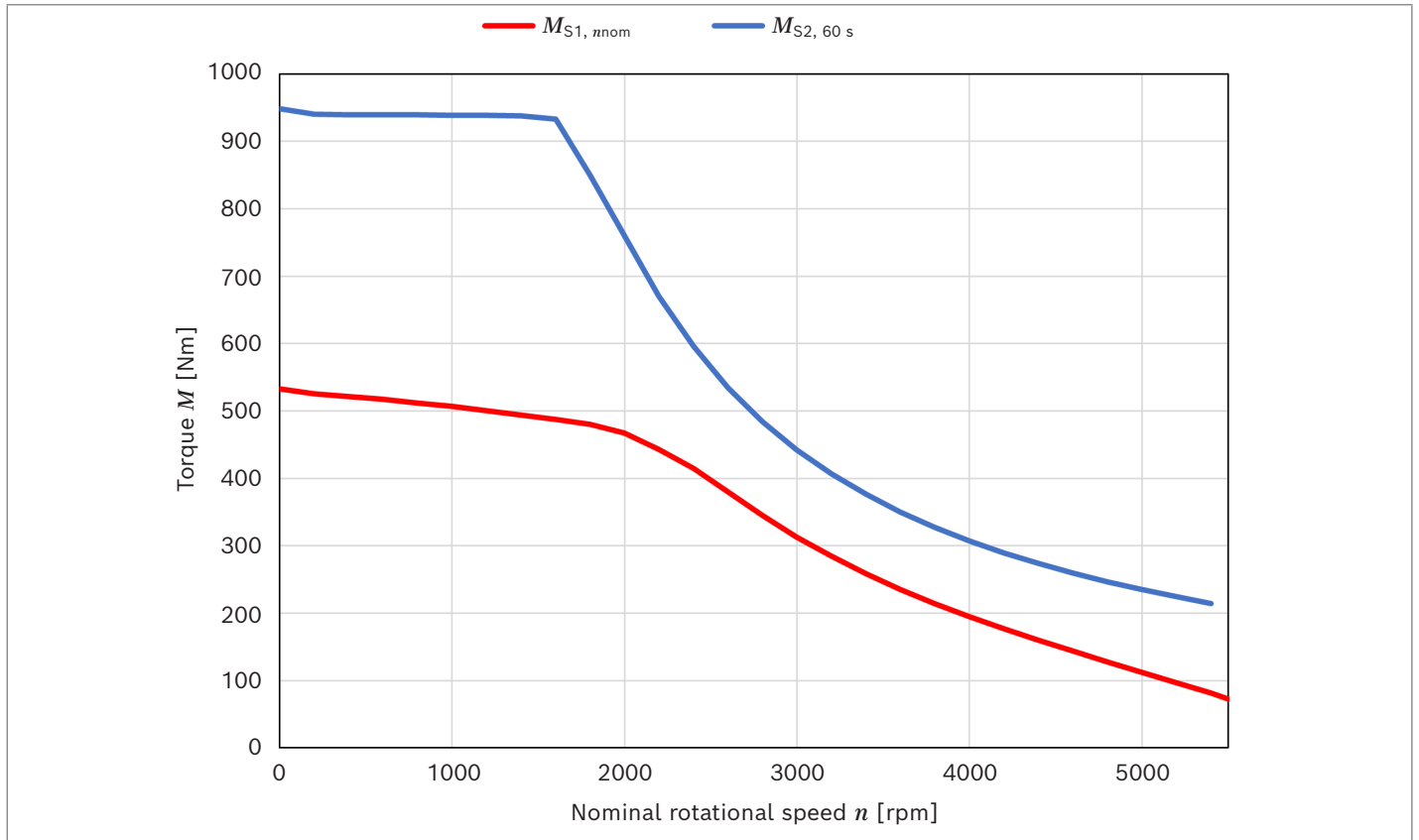

▼ **Power EMS1-16H20**

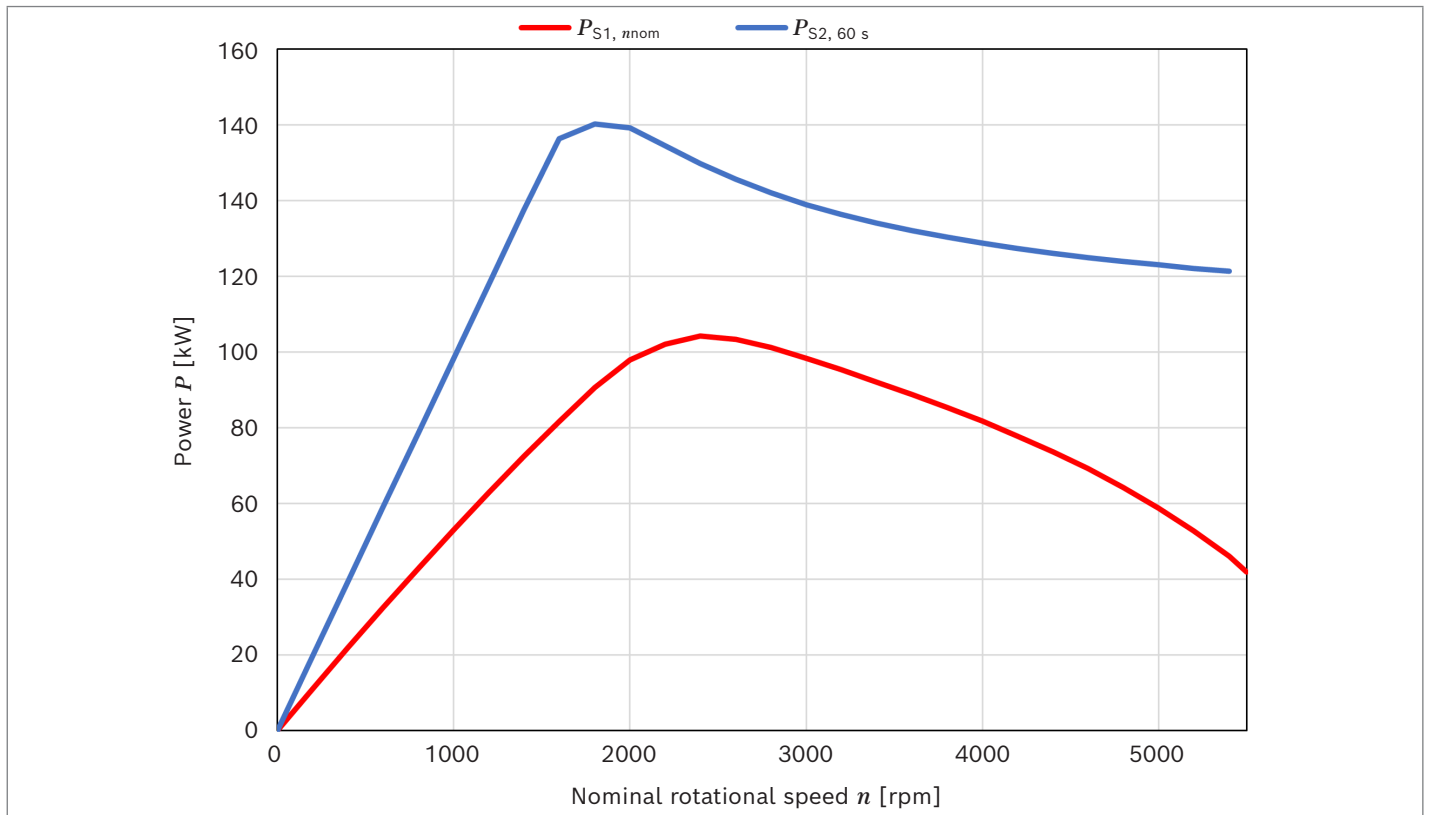

▼ Short circuit current and short circuit braking torque EMS1-16H20

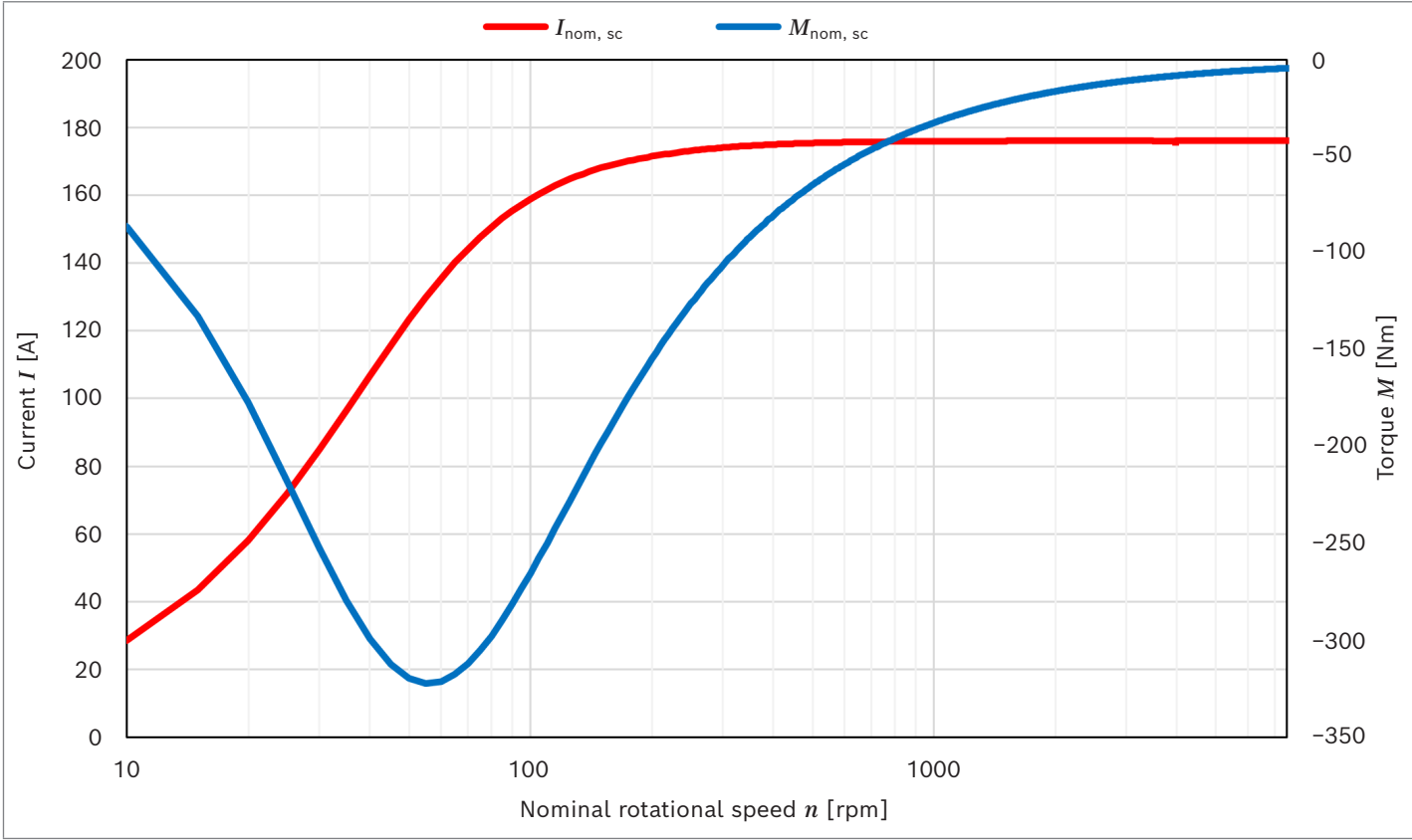

EMS1-16H25

Designation	Symbol	Unit	Value
S1 continuous torque at 200 rpm	$M_{S1, \text{low rotational speed}}$	Nm	523
S1 continuous current at 200 rpm	$I_{S1, \text{low rotational speed}}$	A _{RMS}	196
Nominal rotational speed	n_{nom}	rpm	2500
S1 continuous torque at n_{nom}	$M_{S1, n_{\text{nom}}}$	Nm	435
S1 continuous current at n_{nom}	$I_{S1, n_{\text{nom}}}$	A _{RMS}	169
S1 continuous power at n_{nom}	$P_{S1, n_{\text{nom}}}$	kW	114
S1 continuous efficiency at n_{nom}	$\eta_{S1, n_{\text{nom}}}$	%	95.81
S2 for 60s torque (maximum torque) ¹⁾	$M_{S2, 60 \text{ s}}$	Nm	948
S2 for 60s current (maximum current) ¹⁾	$I_{S2, 60 \text{ s}}$	A _{RMS}	413
S2 for 60s power (maximum power) ¹⁾	$P_{S2, 60 \text{ s}}$	kW	202
Maximum rotational speed	n_{max}	rpm	5500
S1 continuous torque at n_{max}	$M_{S1, n_{\text{max}}}$	Nm	109
S1 continuous current at n_{max}	$I_{S1, n_{\text{max}}}$	A _{RMS}	94
S1 continuous power at n_{max}	$P_{S1, \text{max}}$	kW	63
S1 continuous efficiency at n_{max}	$\eta_{S1, n_{\text{max}}}$	%	94.61
S1 continuous torque at $P_{S1, \text{max}}$	$M_{S1, P_{\text{max}}}$	Nm	400
S1 continuous current at $P_{S1, \text{max}}$	$I_{S1, P_{\text{max}}}$	A _{RMS}	161
S1 continuous power at $P_{S1, \text{max}}$	$P_{S1, P_{\text{max}}}$	kW	115
S1 continuous speed at $P_{S1, \text{max}}$	$n_{S1, P_{\text{max}}}$	%	2750
S1 continuous efficiency at $P_{S1, \text{max}}$	$\eta_{S1, P_{\text{max}}}$	%	96.02
Short circuit braking torque at nominal rotational speed ²⁾	$M_{\text{nom, sc}}$	Nm	13
Short circuit current at nominal speed ²⁾	$I_{\text{nom, sc}}$	A _{RMS}	220
Maximum short circuit braking torque ²⁾	$M_{\text{max, sc}}$	Nm	322
Maximum short circuit current ²⁾	$I_{\text{max, sc}}$	A _{RMS}	220
DC supply voltage	V_{DC}	V	700
Voltage for motor phases (outer conductor-outer conductor – RMS)	V_{LL}	V _{RMS}	475

Electric	Symbol	Unit	Value
Number of poles			8
Phase-phase voltage constant at 20 °C	k_{EMK}	V _{RMS} /1000 rpm	141
Torque constant at 25 °C	k_{T}	Nm/A _{RMS}	2.76
Synchronous inductance (d-axis) at rated current	L_{d}	mH	0.83
Synchronous inductance (q-axis) at rated current	L_{q}	mH	2.54
Stator winding resistance (phase) at 20 °C	R_{LL}	Ω	0.0455
Cogging torque (unskewed)	M_{cog}	Nm	16.08
Torque ripple	$M_{\text{Pk-Pk}}$	Nm	11.56

1) For the S2 calculation, the starting temperature of the components is assumed to be 25 °C.

2) Magnet temperature at 20 °C

▼ **Torque EMS1-16H25**

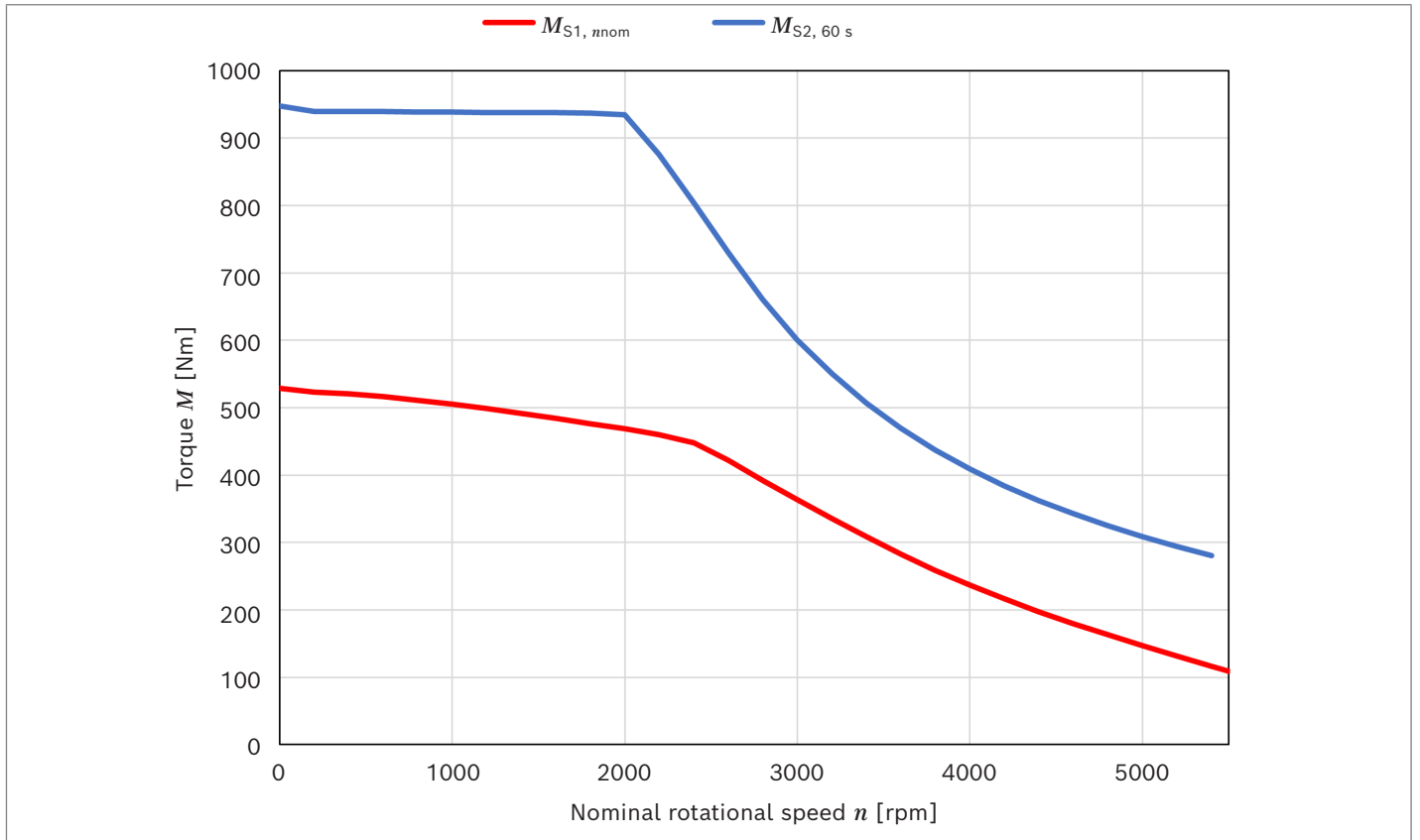

▼ **Power EMS1-16H25**

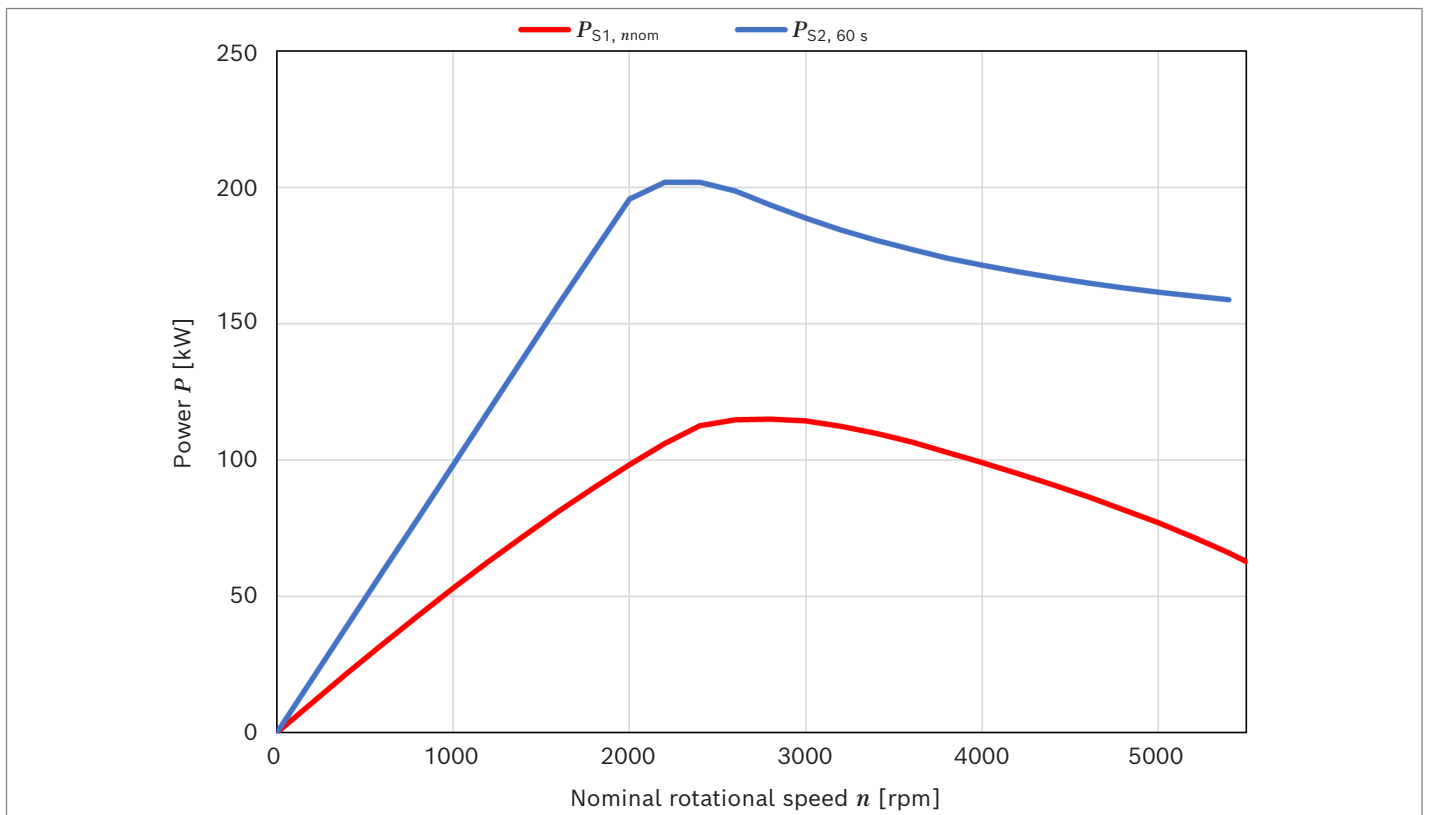

▼ **Short circuit current and short circuit braking torque EMS1-16H25**

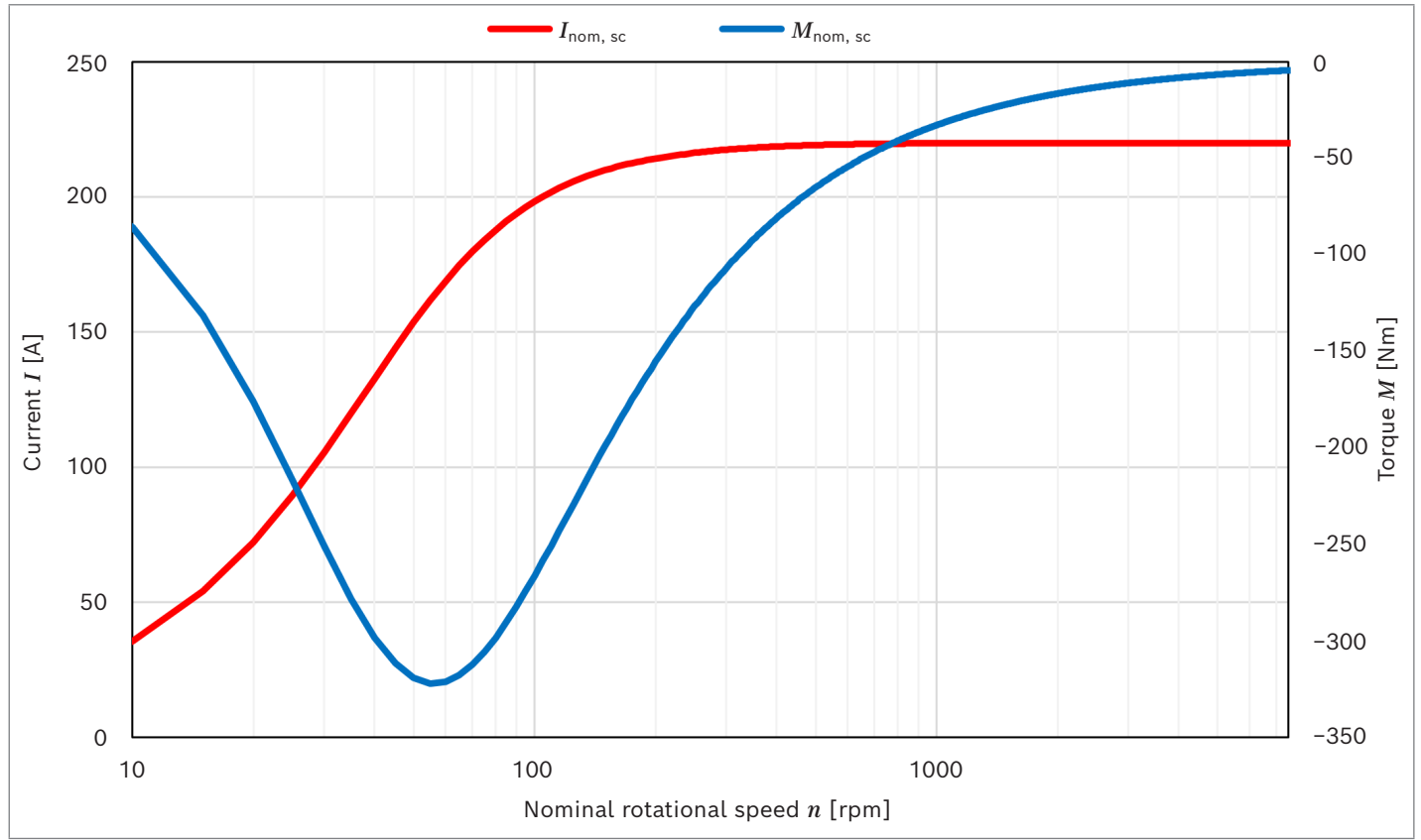

EMS1-16J10

Designation	Symbol	Unit	Value
S1 continuous torque at 200 rpm	$M_{S1, \text{low rotational speed}}$	Nm	638
S1 continuous current at 200 rpm	$I_{S1, \text{low rotational speed}}$	A _{RMS}	96
Nominal rotational speed	n_{nom}	rpm	1000
S1 continuous torque at n_{nom}	$M_{S1, n_{\text{nom}}}$	Nm	598
S1 continuous current at n_{nom}	$I_{S1, n_{\text{nom}}}$	A _{RMS}	93
S1 continuous power at n_{nom}	$P_{S1, n_{\text{nom}}}$	kW	63
S1 continuous efficiency at n_{nom}	$\eta_{S1, n_{\text{nom}}}$	%	92.80
S2 for 60s torque (maximum torque) ¹⁾	$M_{S2, 60 \text{ s}}$	Nm	1185
S2 for 60s current (maximum current) ¹⁾	$I_{S2, 60 \text{ s}}$	A _{RMS}	207
S2 for 60s power (maximum power) ¹⁾	$P_{S2, 60 \text{ s}}$	kW	97
Maximum rotational speed	n_{max}	rpm	5500
S1 continuous torque at n_{max}	$M_{S1, n_{\text{max}}}$	Nm	0
S1 continuous current at n_{max}	$I_{S1, n_{\text{max}}}$	A _{RMS}	0
S1 continuous power at n_{max}	$P_{S1, n_{\text{max}}}$	kW	0
S1 continuous efficiency at n_{max}	$\eta_{S1, n_{\text{max}}}$	%	0.00
S1 continuous torque at $P_{S1, \text{max}}$	$M_{S1, P_{\text{max}}}$	Nm	398
S1 continuous current at $P_{S1, \text{max}}$	$I_{S1, P_{\text{max}}}$	A _{RMS}	92
S1 continuous power at $P_{S1, \text{max}}$	$P_{S1, P_{\text{max}}}$	kW	69
S1 continuous speed at $P_{S1, \text{max}}$	$n_{S1, P_{\text{max}}}$	%	1650
S1 continuous efficiency at $P_{S1, \text{max}}$	$\eta_{S1, P_{\text{max}}}$	%	93.18
Short circuit braking torque at nominal rotational speed ²⁾	$M_{\text{nom, sc}}$	Nm	38
Short circuit current at nominal speed ²⁾	$I_{\text{nom, sc}}$	A _{RMS}	110
Maximum short circuit braking torque ²⁾	$M_{\text{max, sc}}$	Nm	404
Maximum short circuit current ²⁾	$I_{\text{max, sc}}$	A _{RMS}	110
DC supply voltage	V_{DC}	V	700
Voltage for motor phases (outer conductor-outer conductor – RMS)	V_{LL}	V _{RMS}	475

Electric	Symbol	Unit	Value
Number of poles			8
Phase-phase voltage constant at 20 °C	k_{EMK}	V _{RMS} / 1000 rpm	352.61
Torque constant at 25 °C	k_{T}	Nm / A _{RMS}	6.9
Synchronous inductance (d-axis) at rated current	L_{d}	mH	4.08
Synchronous inductance (q-axis) at rated current	L_{q}	mH	9.51
Stator winding resistance (phase) at 20 °C	R_{LL}	Ω	0.2187
Cogging torque (unskewed)	M_{cog}	Nm	20.1
Torque ripple	$M_{\text{Pk-Pk}}$	Nm	15.42

1) For the S2 calculation, the starting temperature of the components is assumed to be 25 °C.

2) Magnet temperature at 20 °C

▼ **Torque EMS1-16J10**

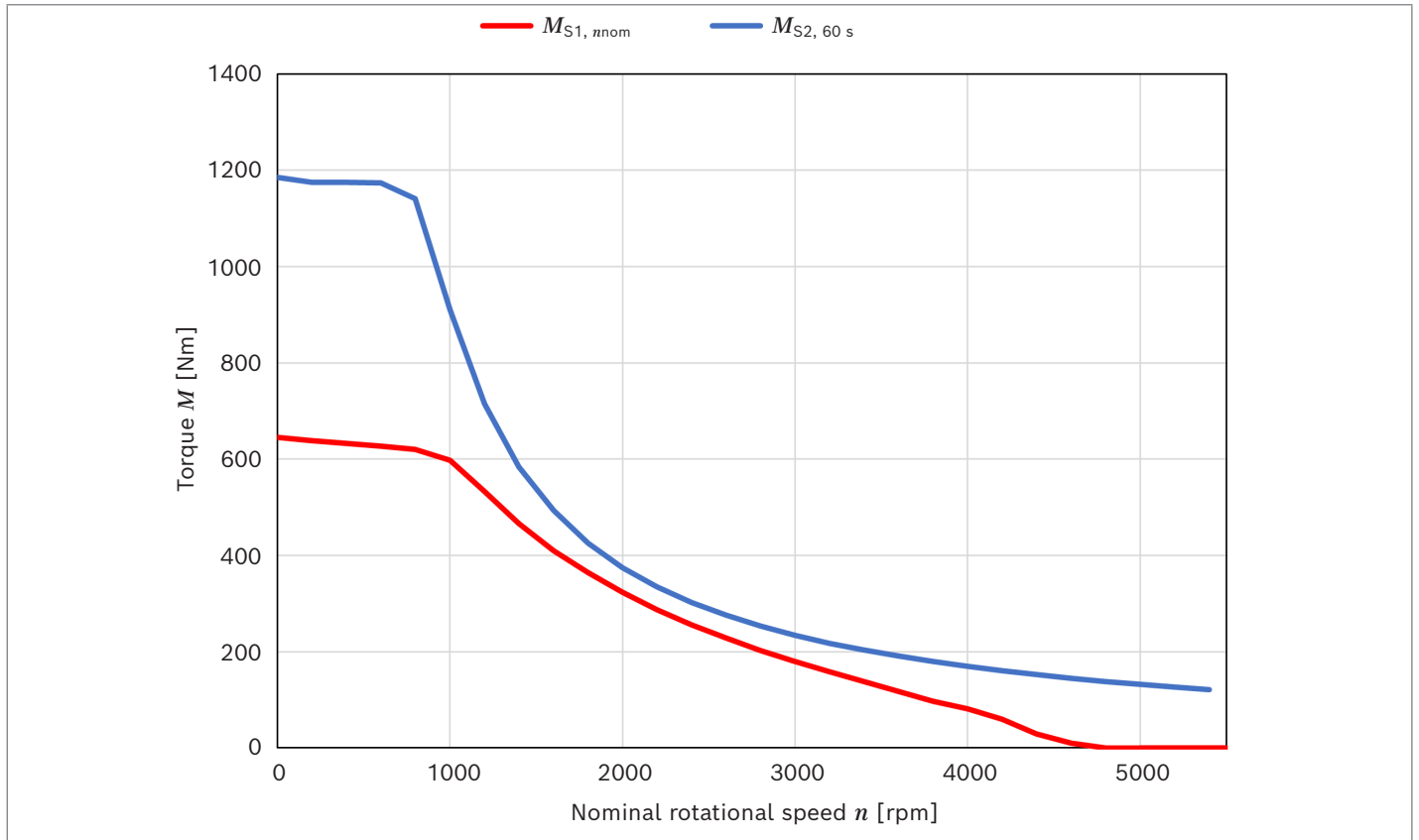

▼ **Power EMS1-16J10**

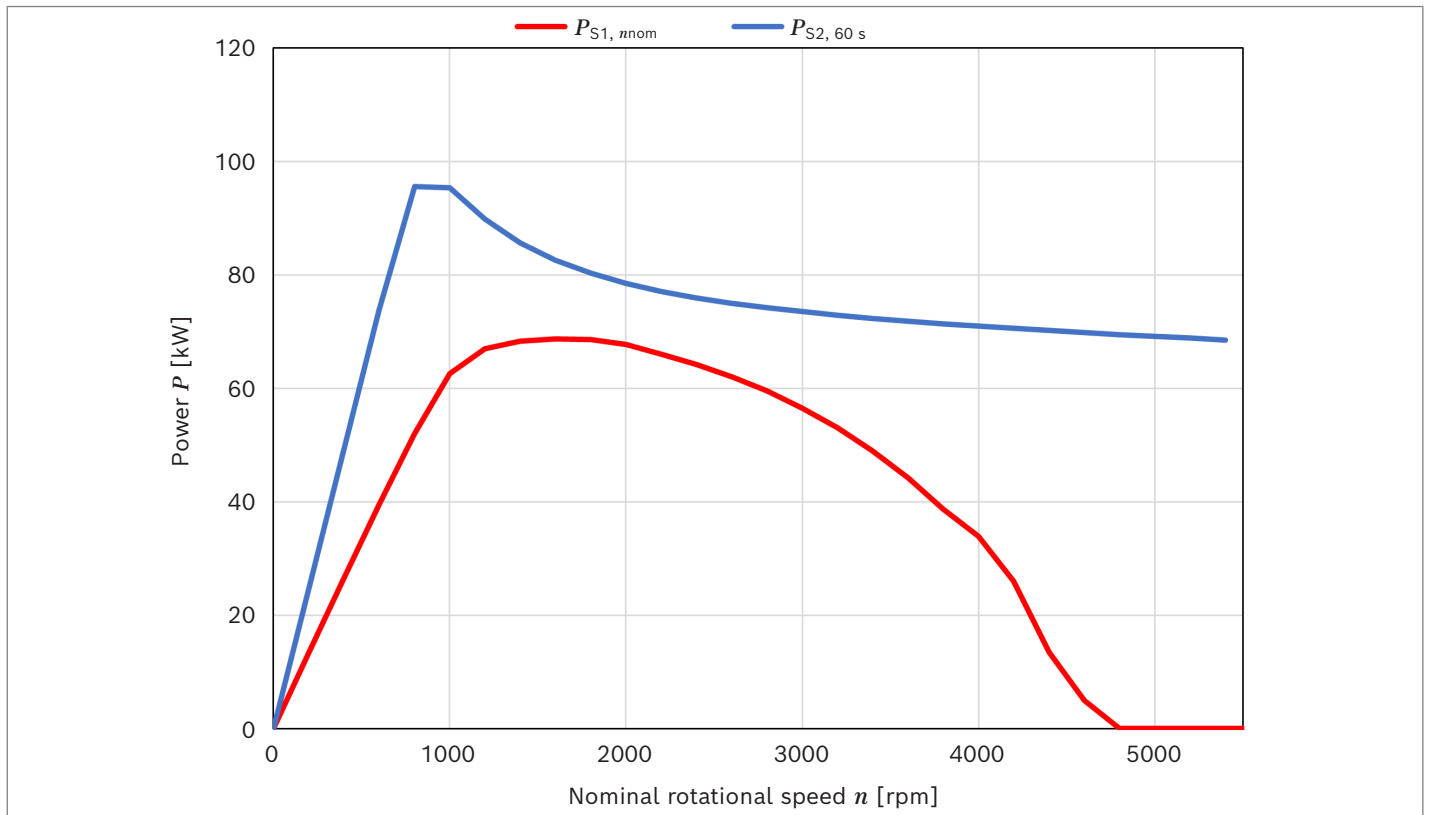

▼ Short circuit current and short circuit braking torque EMS1-16J10

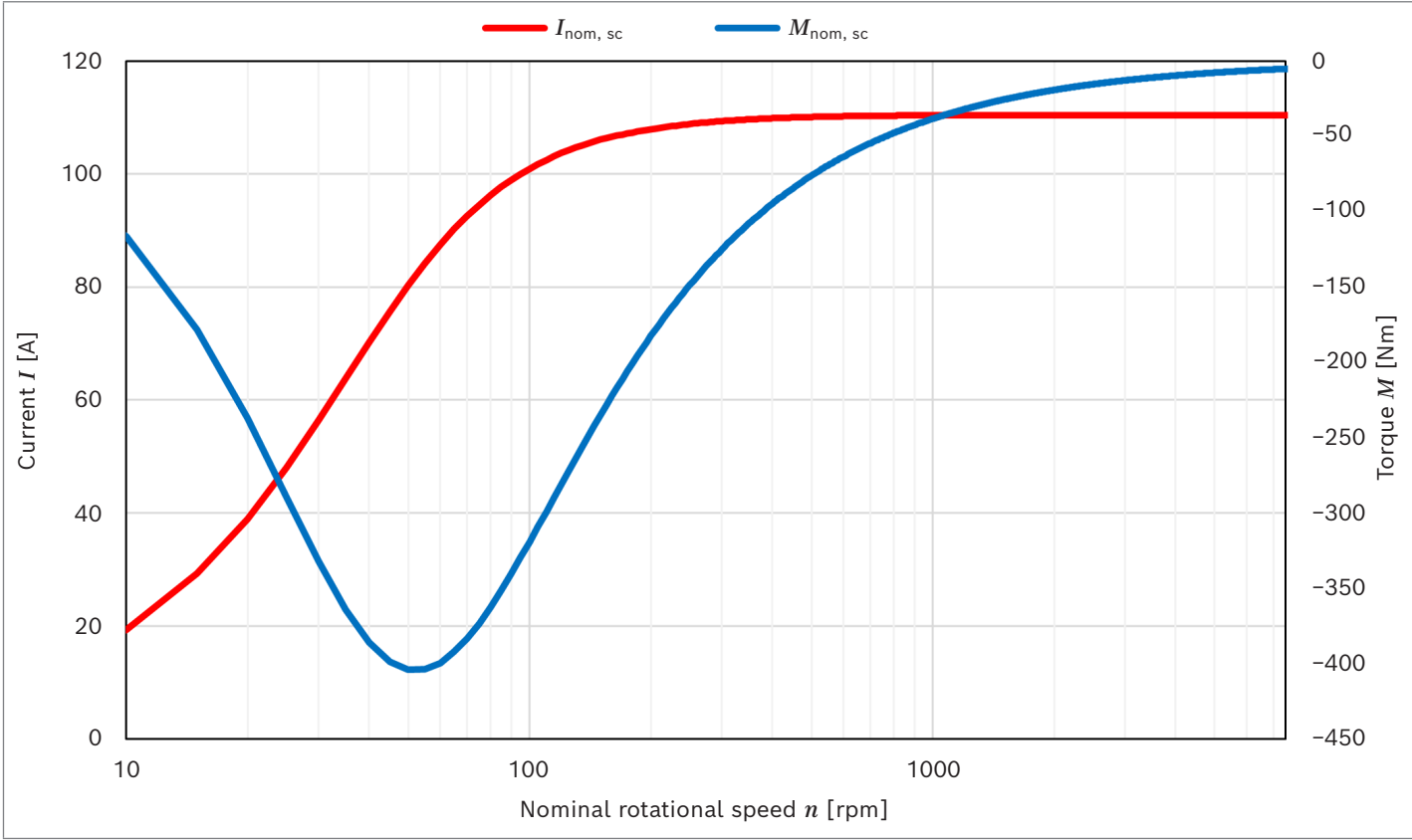

EMS1-16J15

Designation	Symbol	Unit	Value
S1 continuous torque at 200 rpm	$M_{S1, \text{low rotational speed}}$	Nm	636
S1 continuous current at 200 rpm	$I_{S1, \text{low rotational speed}}$	A _{RMS}	139
Nominal rotational speed	n_{nom}	rpm	1500
S1 continuous torque at n_{nom}	$M_{S1, n_{\text{nom}}}$	Nm	572
S1 continuous current at n_{nom}	$I_{S1, n_{\text{nom}}}$	A _{RMS}	132
S1 continuous power at n_{nom}	$P_{S1, n_{\text{nom}}}$	kW	90
S1 continuous efficiency at n_{nom}	$\eta_{S1, n_{\text{nom}}}$	%	94.57
S2 for 60s torque (maximum torque) ¹⁾	$M_{S2, 60 \text{ s}}$	Nm	1185
S2 for 60s current (maximum current) ¹⁾	$I_{S2, 60 \text{ s}}$	A _{RMS}	301
S2 for 60s power (maximum power) ¹⁾	$P_{S2, 60 \text{ s}}$	kW	145
Maximum rotational speed	n_{max}	rpm	5500
S1 continuous torque at n_{max}	$M_{S1, n_{\text{max}}}$	Nm	0
S1 continuous current at n_{max}	$I_{S1, n_{\text{max}}}$	A _{RMS}	17
S1 continuous power at n_{max}	$P_{S1, \text{max}}$	kW	0
S1 continuous efficiency at n_{max}	$\eta_{S1, n_{\text{max}}}$	%	0.00
S1 continuous torque at $P_{S1, \text{max}}$	$M_{S1, P_{\text{max}}}$	Nm	467
S1 continuous current at $P_{S1, \text{max}}$	$I_{S1, P_{\text{max}}}$	A _{RMS}	129
S1 continuous power at $P_{S1, \text{max}}$	$P_{S1, P_{\text{max}}}$	kW	97
S1 continuous speed at $P_{S1, \text{max}}$	$n_{S1, P_{\text{max}}}$	%	1980
S1 continuous efficiency at $P_{S1, \text{max}}$	$\eta_{S1, P_{\text{max}}}$	%	94.95
Short circuit braking torque at nominal rotational speed ²⁾	$M_{\text{nom, sc}}$	Nm	26
Short circuit current at nominal speed ²⁾	$I_{\text{nom, sc}}$	A _{RMS}	161
Maximum short circuit braking torque ²⁾	$M_{\text{max, sc}}$	Nm	404
Maximum short circuit current ²⁾	$I_{\text{max, sc}}$	A _{RMS}	161
DC supply voltage	V_{DC}	V	700
Voltage for motor phases (outer conductor-outer conductor – RMS)	V_{LL}	V _{RMS}	475

Electric	Symbol	Unit	Value
Number of poles			8
Phase-phase voltage constant at 20 °C	k_{EMK}	V _{RMS} /1000 rpm	242.4
Torque constant at 25 °C	k_{T}	Nm/A _{RMS}	4.74
Synchronous inductance (d-axis) at rated current	L_{d}	mH	1.94
Synchronous inductance (q-axis) at rated current	L_{q}	mH	5.92
Stator winding resistance (phase) at 20 °C	R_{LL}	Ω	0.1
Cogging torque (unskewed)	M_{cog}	Nm	20.1
Torque ripple	$M_{\text{Pk-Pk}}$	Nm	15.33

1) For the S2 calculation, the starting temperature of the components is assumed to be 25 °C.

2) Magnet temperature at 20 °C

▼ Torque EMS1-16J15

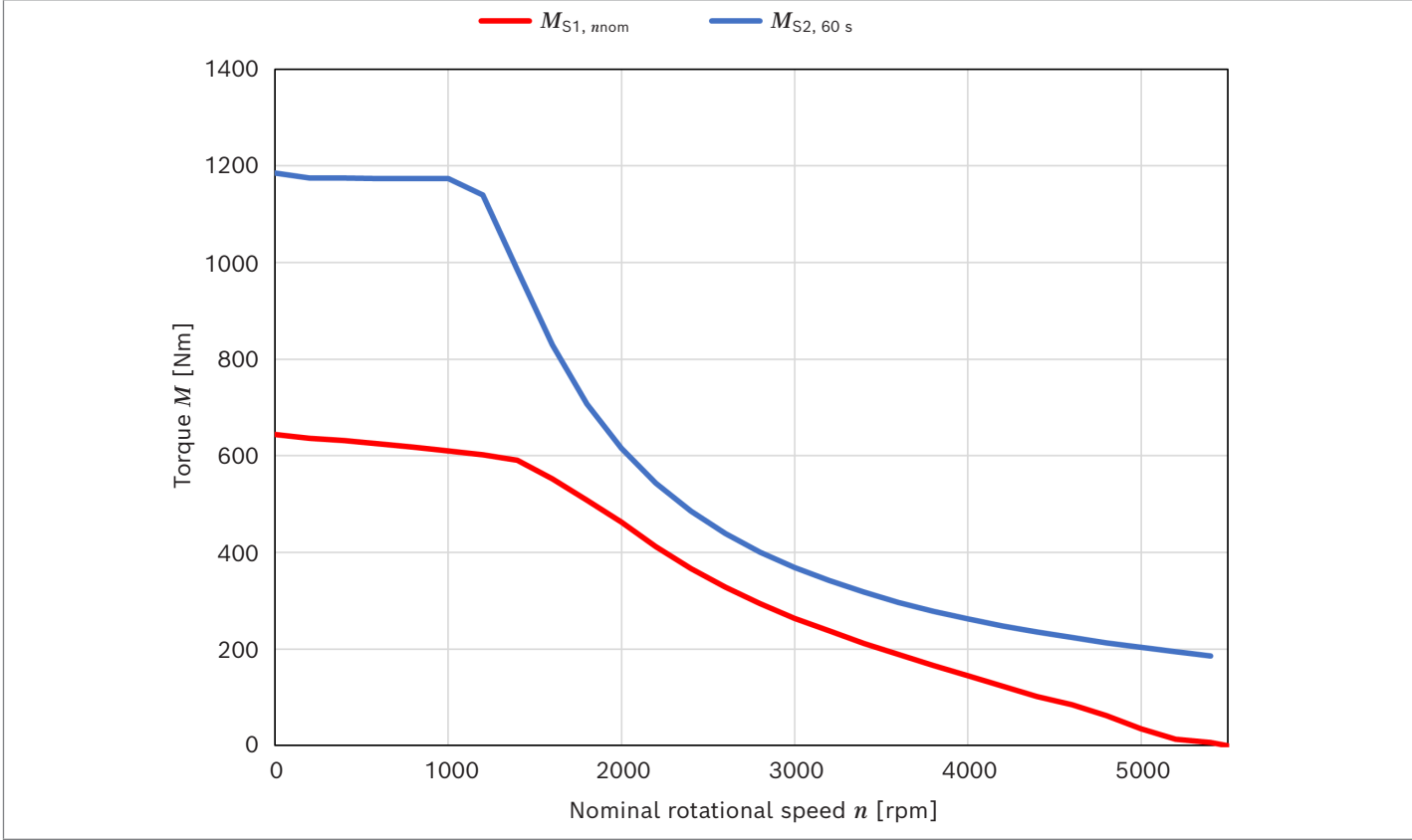

▼ Power EMS1-16J15

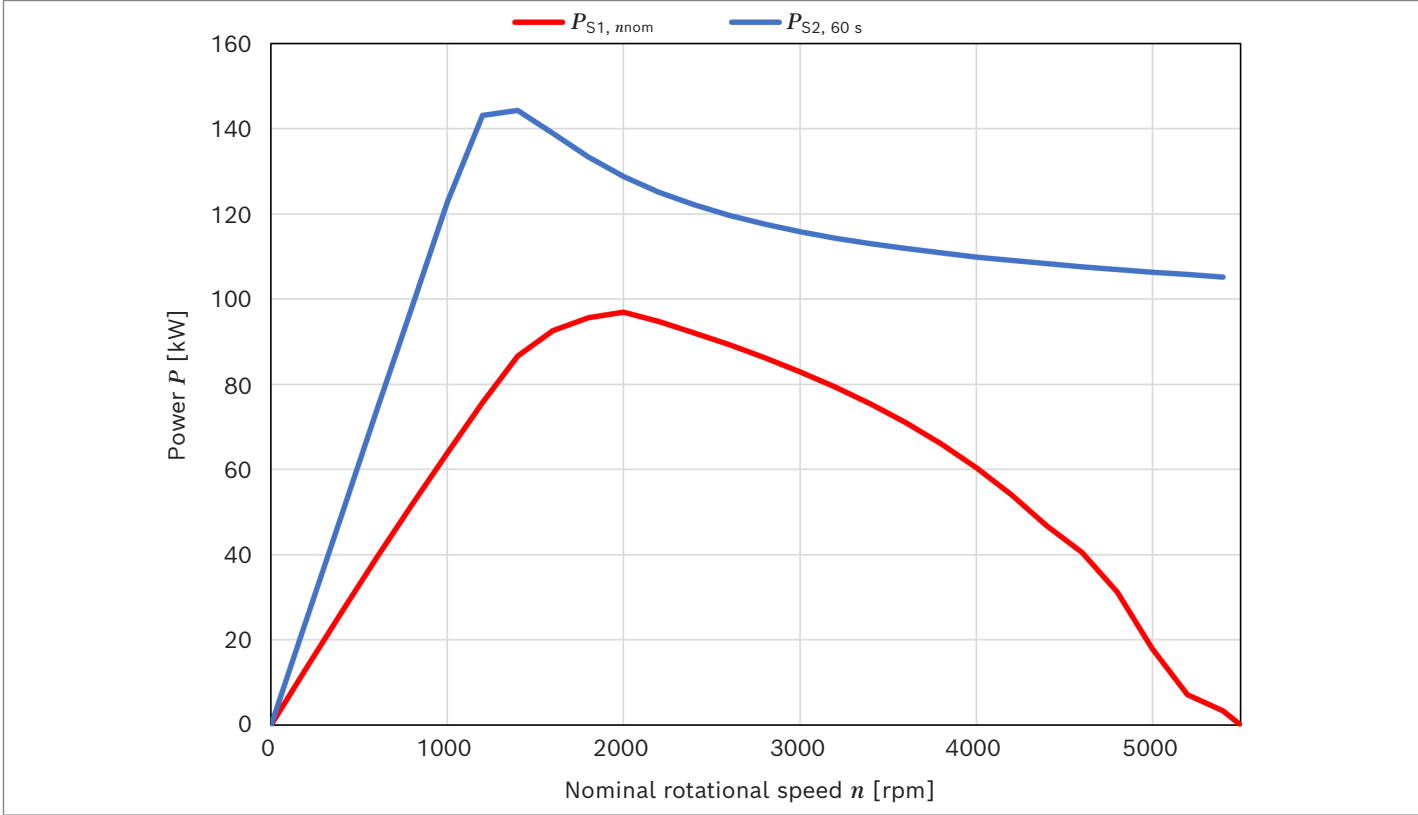

▼ **Short circuit current and short circuit braking torque EMS1-16J15**

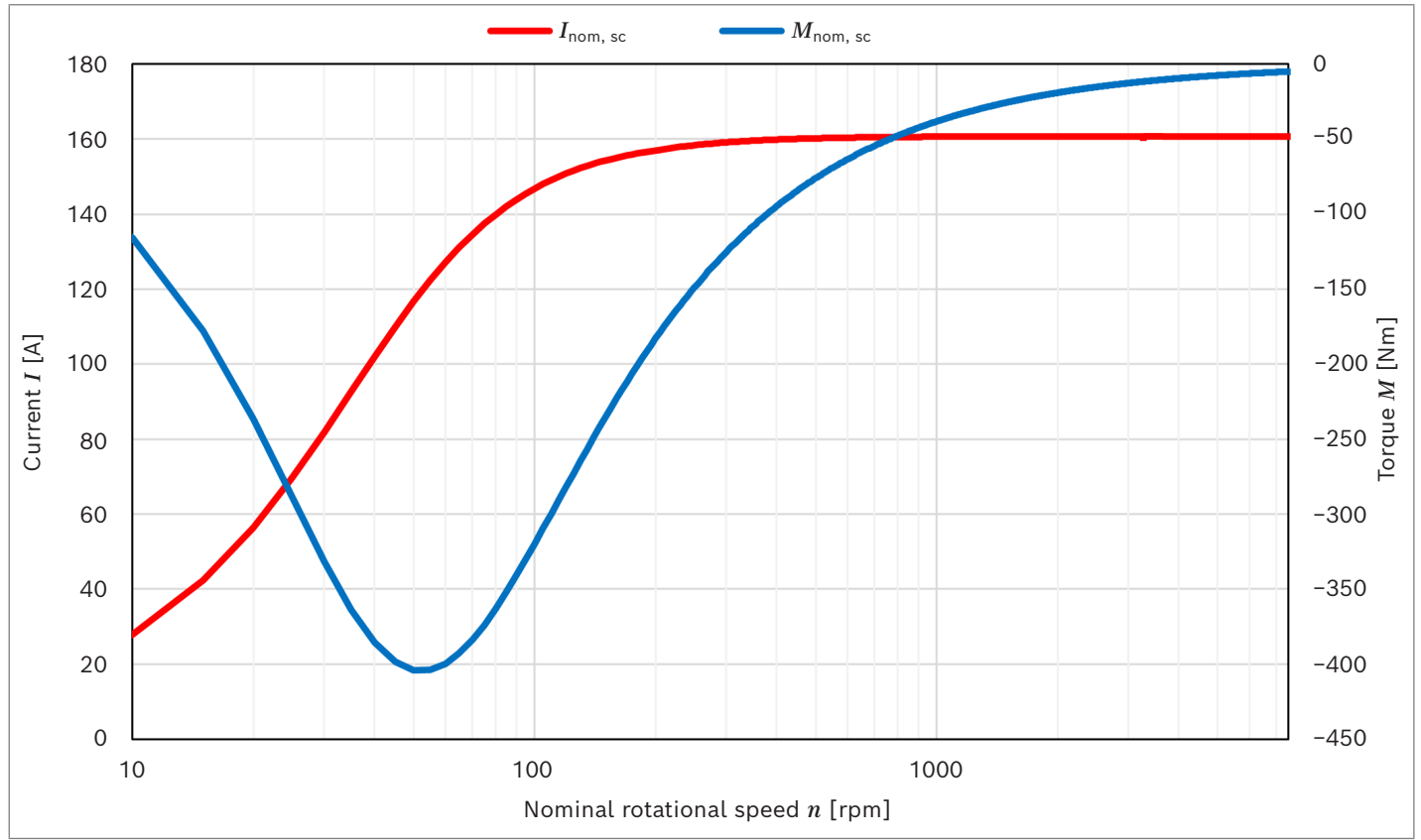

EMS1-16J20

Designation	Symbol	Unit	Value
S1 continuous torque at 200 rpm	$M_{S1, \text{low rotational speed}}$	Nm	638
S1 continuous current at 200 rpm	$I_{S1, \text{low rotational speed}}$	A _{RMS}	192
Nominal rotational speed	n_{nom}	rpm	2000
S1 continuous torque at n_{nom}	$M_{S1, n_{\text{nom}}}$	Nm	557
S1 continuous current at n_{nom}	$I_{S1, n_{\text{nom}}}$	A _{RMS}	174
S1 continuous power at n_{nom}	$P_{S1, n_{\text{nom}}}$	kW	117
S1 continuous efficiency at n_{nom}	$\eta_{S1, n_{\text{nom}}}$	%	95.45
S2 for 60s torque (maximum torque) ¹⁾	$M_{S2, 60 \text{ s}}$	Nm	1185
S2 for 60s current (maximum current) ¹⁾	$I_{S2, 60 \text{ s}}$	A _{RMS}	413
S2 for 60s power (maximum power) ¹⁾	$P_{S2, 60 \text{ s}}$	kW	202
Maximum rotational speed	n_{max}	rpm	5500
S1 continuous torque at n_{max}	$M_{S1, n_{\text{max}}}$	Nm	56
S1 continuous current at n_{max}	$I_{S1, n_{\text{max}}}$	A _{RMS}	88
S1 continuous power at n_{max}	$P_{S1, n_{\text{max}}}$	kW	32
S1 continuous efficiency at n_{max}	$\eta_{S1, n_{\text{max}}}$	%	88.84
S1 continuous torque at $P_{S1, \text{max}}$	$M_{S1, P_{\text{max}}}$	Nm	485
S1 continuous current at $P_{S1, \text{max}}$	$I_{S1, P_{\text{max}}}$	A _{RMS}	163
S1 continuous power at $P_{S1, \text{max}}$	$P_{S1, P_{\text{max}}}$	kW	120
S1 continuous speed at $P_{S1, \text{max}}$	$n_{S1, P_{\text{max}}}$	%	2365
S1 continuous efficiency at $P_{S1, \text{max}}$	$\eta_{S1, P_{\text{max}}}$	%	95.90
Short circuit braking torque at nominal rotational speed ²⁾	$M_{\text{nom, sc}}$	Nm	19
Short circuit current at nominal speed ²⁾	$I_{\text{nom, sc}}$	A _{RMS}	221
Maximum short circuit braking torque ²⁾	$M_{\text{max, sc}}$	Nm	404
Maximum short circuit current ²⁾	$I_{\text{max, sc}}$	A _{RMS}	221
DC supply voltage	V_{DC}	V	700
Voltage for motor phases (outer conductor-outer conductor – RMS)	V_{LL}	V _{RMS}	475

Electric	Symbol	Unit	Value
Number of poles			8
Phase-phase voltage constant at 20 °C	k_{EMK}	V _{RMS} / 1000 rpm	176.3
Torque constant at 25 °C	k_{T}	Nm / A _{RMS}	3.45
Synchronous inductance (d-axis) at rated current	L_{d}	mH	1.03
Synchronous inductance (q-axis) at rated current	L_{q}	mH	3.18
Stator winding resistance (phase) at 20 °C	R_{LL}	Ω	0.0547
Cogging torque (unskewed)	M_{cog}	Nm	20.1
Torque ripple	$M_{\text{Pk-Pk}}$	Nm	14.31

1) For the S2 calculation, the starting temperature of the components is assumed to be 25 °C.

2) Magnet temperature at 20 °C

▼ **Torque EMS1-16J20**

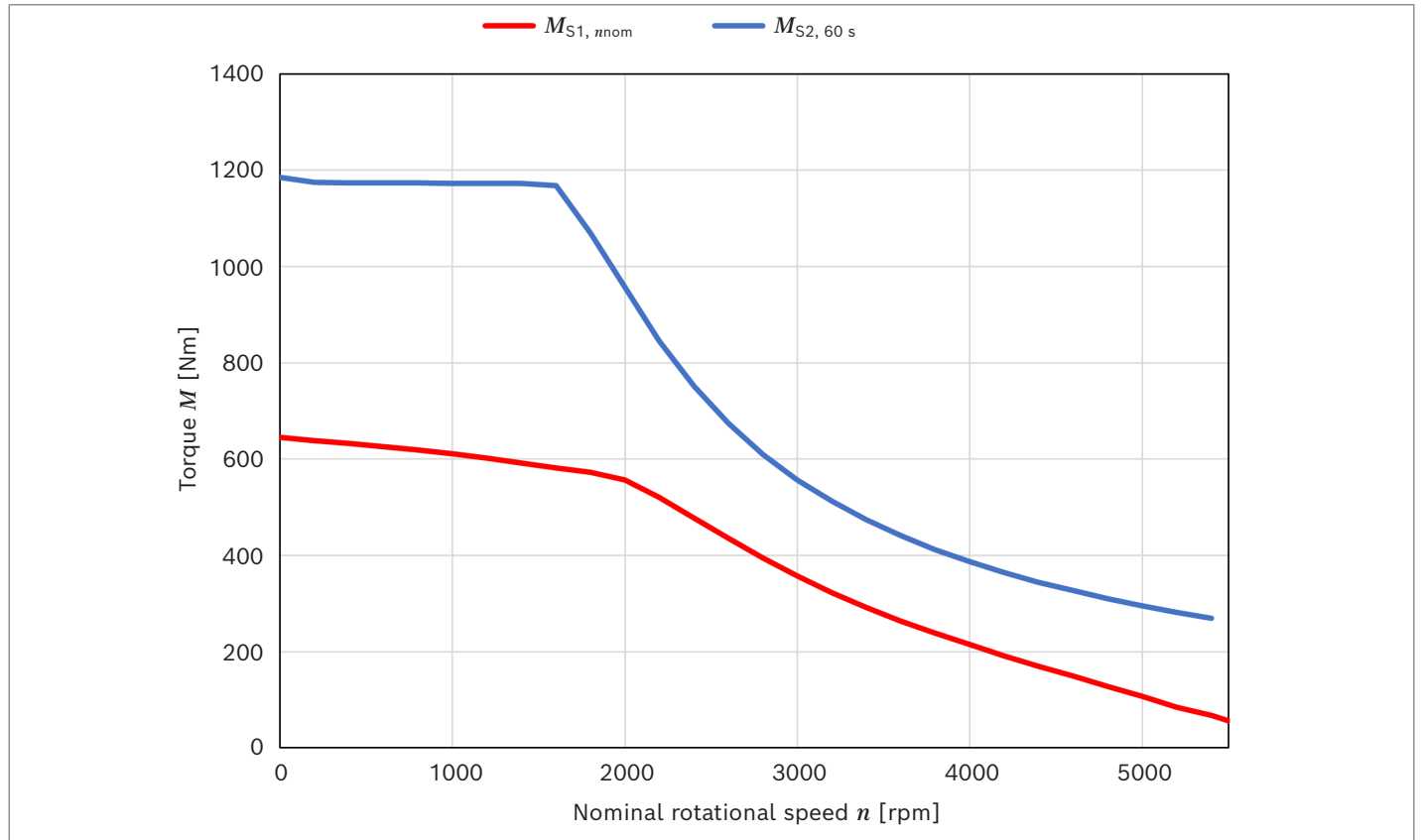

▼ **Power EMS1-16J20**

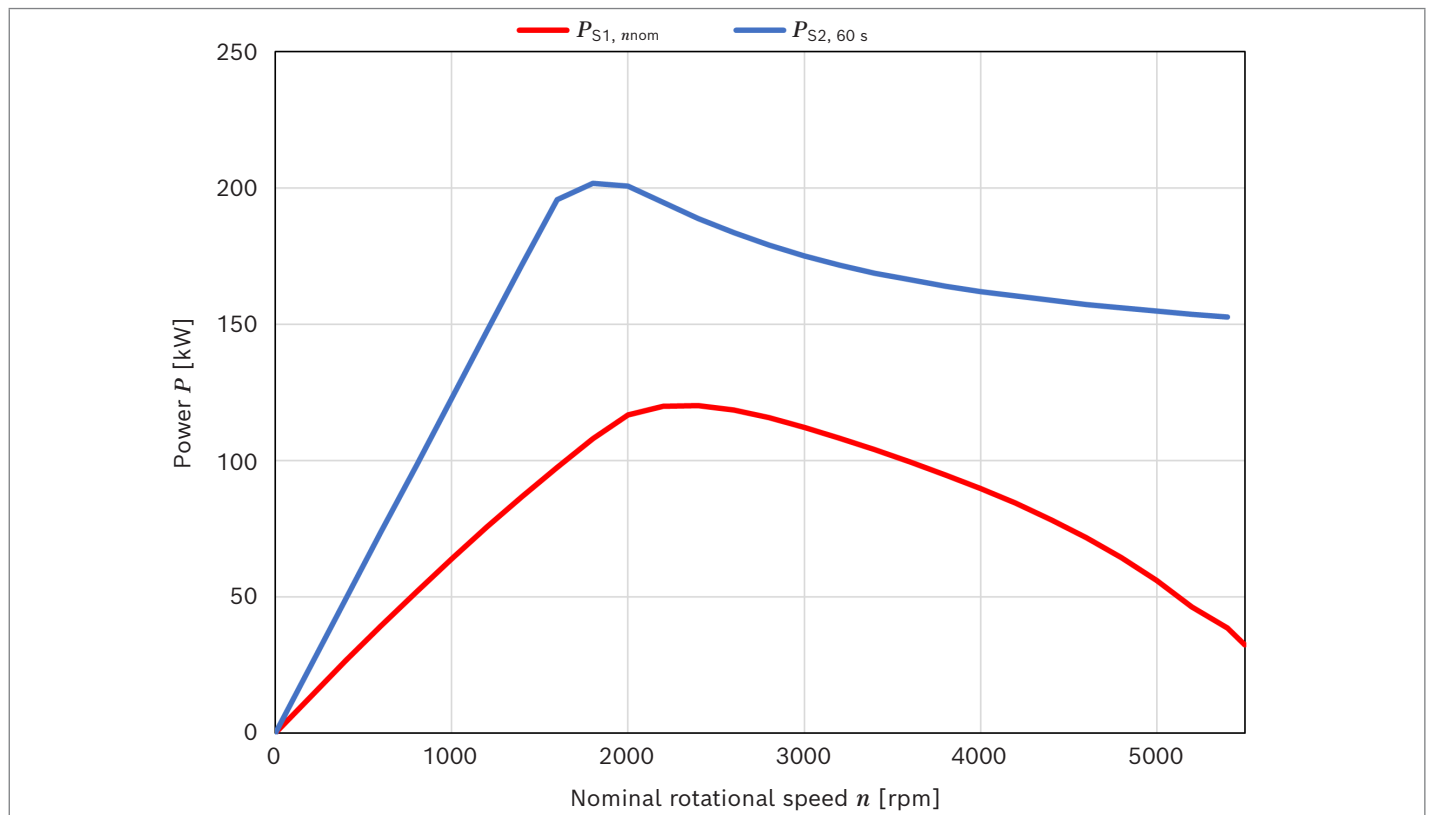

▼ Short circuit current and short circuit braking torque EMS1-16J20

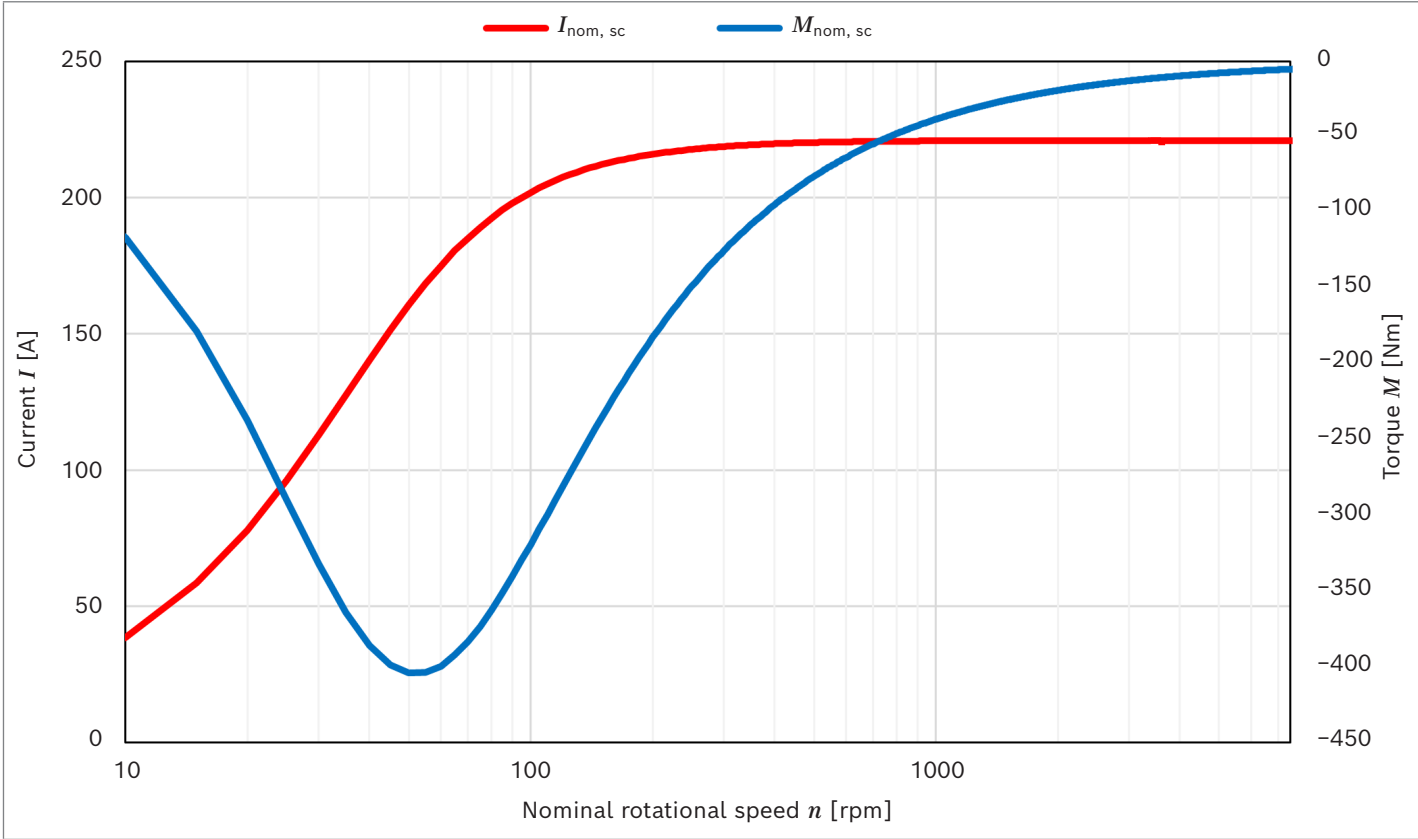

EMS1-16J25

Designation	Symbol	Unit	Value
S1 continuous torque at 200 rpm	$M_{S1, \text{low rotational speed}}$	Nm	640
S1 continuous current at 200 rpm	$I_{S1, \text{low rotational speed}}$	A _{RMS}	237
Nominal rotational speed	n_{nom}	rpm	2500
S1 continuous torque at n_{nom}	$M_{S1, n_{\text{nom}}}$	Nm	512
S1 continuous current at n_{nom}	$I_{S1, n_{\text{nom}}}$	A _{RMS}	196
S1 continuous power at n_{nom}	$P_{S1, n_{\text{nom}}}$	kW	134
S1 continuous efficiency at n_{nom}	$\eta_{S1, n_{\text{nom}}}$	%	96.24
S2 for 60s torque (maximum torque) ¹⁾	$M_{S2, 60 \text{ s}}$	Nm	1184
S2 for 60s current (maximum current) ¹⁾	$I_{S2, 60 \text{ s}}$	A _{RMS}	509
S2 for 60s power (maximum power) ¹⁾	$P_{S2, 60 \text{ s}}$	kW	250
Maximum rotational speed	n_{max}	rpm	5500
S1 continuous torque at n_{max}	$M_{S1, n_{\text{max}}}$	Nm	122
S1 continuous current at n_{max}	$I_{S1, n_{\text{max}}}$	A _{RMS}	110
S1 continuous power at n_{max}	$P_{S1, \text{max}}$	kW	70
S1 continuous efficiency at n_{max}	$\eta_{S1, n_{\text{max}}}$	%	94.85
S1 continuous torque at $P_{S1, \text{max}}$	$M_{S1, P_{\text{max}}}$	Nm	471
S1 continuous current at $P_{S1, \text{max}}$	$I_{S1, P_{\text{max}}}$	A _{RMS}	188
S1 continuous power at $P_{S1, \text{max}}$	$P_{S1, P_{\text{max}}}$	kW	135
S1 continuous speed at $P_{S1, \text{max}}$	$n_{S1, P_{\text{max}}}$	%	2750
S1 continuous efficiency at $P_{S1, \text{max}}$	$\eta_{S1, P_{\text{max}}}$	%	96.40
Short circuit braking torque at nominal rotational speed ²⁾	$M_{\text{nom, sc}}$	Nm	15
Short circuit current at nominal speed ²⁾	$I_{\text{nom, sc}}$	A _{RMS}	272
Maximum short circuit braking torque ²⁾	$M_{\text{max, sc}}$	Nm	404
Maximum short circuit current ²⁾	$I_{\text{max, sc}}$	A _{RMS}	272
DC supply voltage	V_{DC}	V	700
Voltage for motor phases (outer conductor-outer conductor – RMS)	V_{LL}	V _{RMS}	475

Electric	Symbol	Unit	Value
Number of poles			8
Phase-phase voltage constant at 20 °C	k_{EMK}	V _{RMS} /1000 rpm	143.3
Torque constant at 25 °C	k_{T}	Nm/A _{RMS}	2.8
Synchronous inductance (d-axis) at rated current	L_{d}	mH	0.69
Synchronous inductance (q-axis) at rated current	L_{q}	mH	2.14
Stator winding resistance (phase) at 20 °C	R_{LL}	Ω	0.035
Cogging torque (unskewed)	M_{cog}	Nm	20.1
Torque ripple	$M_{\text{Pk-Pk}}$	Nm	13.36

1) For the S2 calculation, the starting temperature of the components is assumed to be 25 °C.

2) Magnet temperature at 20 °C

▼ **Torque EMS1-16J25**

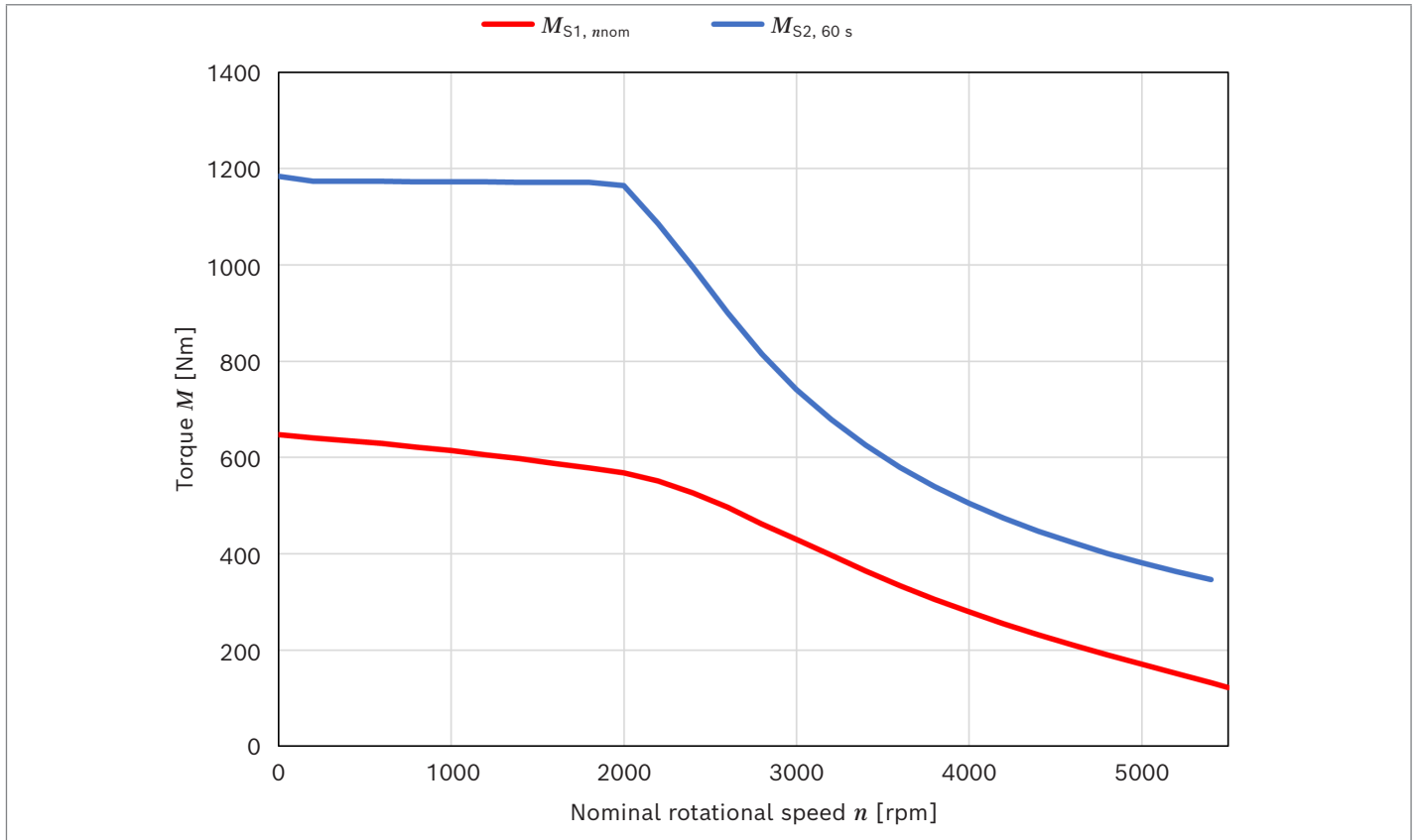

▼ **Power EMS1-16J25**

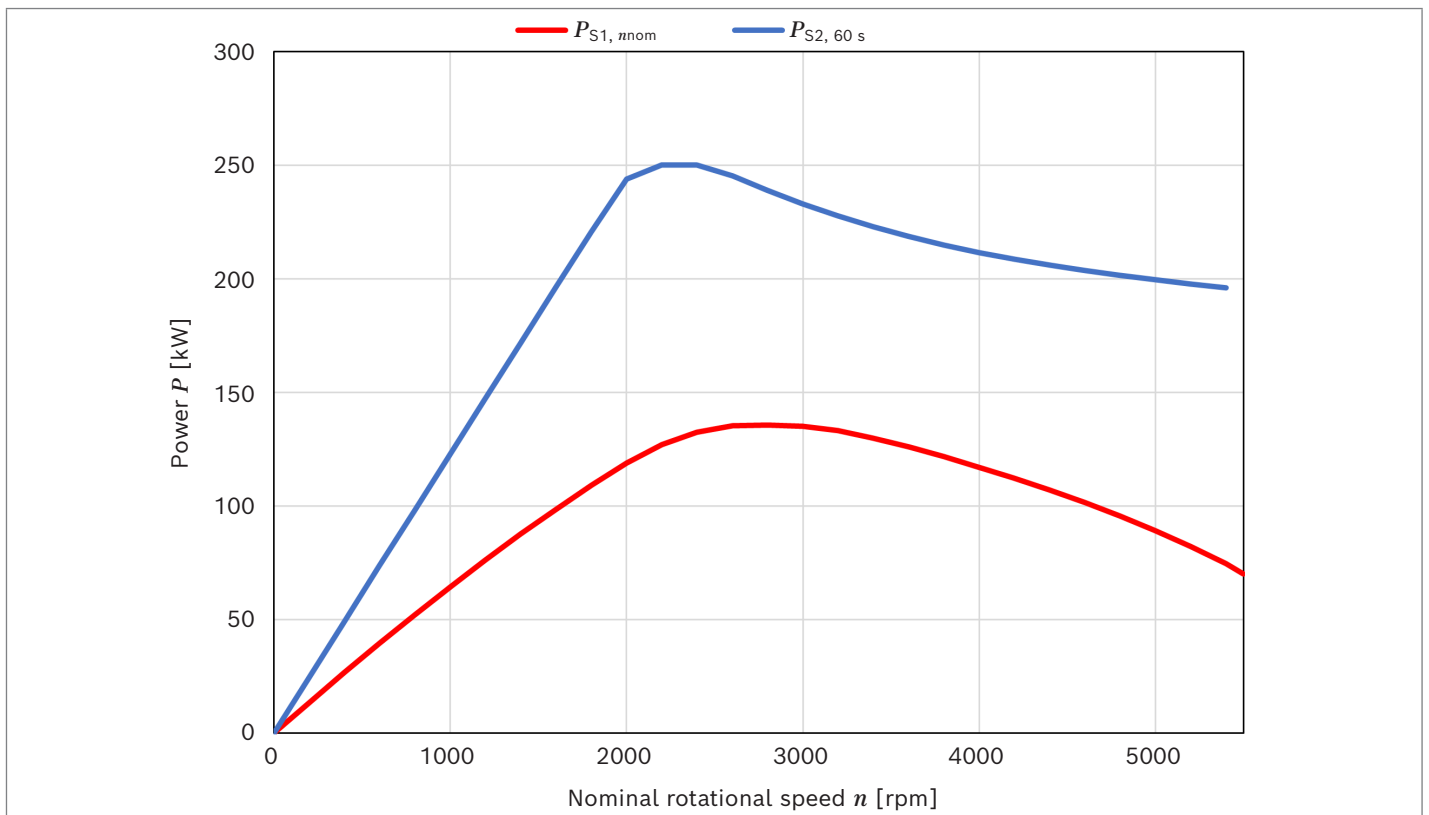

▼ **Short circuit current and short circuit braking torque EMS1-16J25**

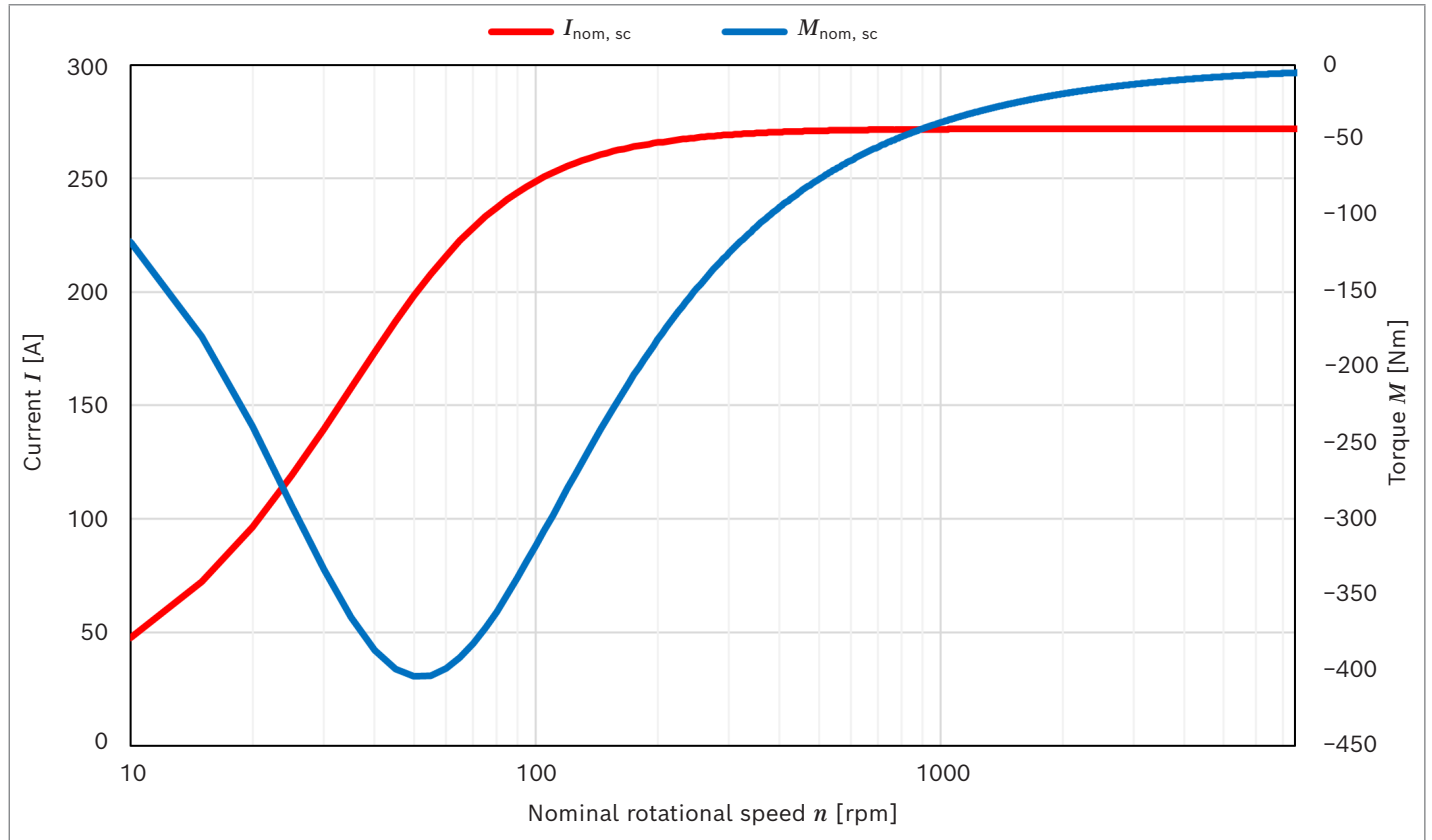

EMS1-16L10

Designation	Symbol	Unit	Value
S1 continuous torque at 200 rpm	$M_{S1, \text{low rotational speed}}$	Nm	748
S1 continuous current at 200 rpm	$I_{S1, \text{low rotational speed}}$	A _{RMS}	115
Nominal rotational speed	n_{nom}	rpm	1000
S1 continuous torque at n_{nom}	$M_{S1, n_{\text{nom}}}$	Nm	705
S1 continuous current at n_{nom}	$I_{S1, n_{\text{nom}}}$	A _{RMS}	112
S1 continuous power at n_{nom}	$P_{S1, n_{\text{nom}}}$	kW	74
S1 continuous efficiency at n_{nom}	$\eta_{S1, n_{\text{nom}}}$	%	93.33
S2 for 60s torque (maximum torque) ¹⁾	$M_{S2, 60 \text{ s}}$	Nm	1421
S2 for 60s current (maximum current) ¹⁾	$I_{S2, 60 \text{ s}}$	A _{RMS}	254
S2 for 60s power (maximum power) ¹⁾	$P_{S2, 60 \text{ s}}$	kW	120
Maximum rotational speed	n_{max}	rpm	5500
S1 continuous torque at n_{max}	$M_{S1, n_{\text{max}}}$	Nm	0
S1 continuous current at n_{max}	$I_{S1, n_{\text{max}}}$	A _{RMS}	0
S1 continuous power at n_{max}	$P_{S1, \text{max}}$	kW	0
S1 continuous efficiency at n_{max}	$\eta_{S1, n_{\text{max}}}$	%	0.00
S1 continuous torque at $P_{S1, \text{max}}$	$M_{S1, P_{\text{max}}}$	Nm	495
S1 continuous current at $P_{S1, \text{max}}$	$I_{S1, P_{\text{max}}}$	A _{RMS}	110
S1 continuous power at $P_{S1, \text{max}}$	$P_{S1, P_{\text{max}}}$	kW	83
S1 continuous speed at $P_{S1, \text{max}}$	$n_{S1, P_{\text{max}}}$	%	1595
S1 continuous efficiency at $P_{S1, \text{max}}$	$\eta_{S1, P_{\text{max}}}$	%	93.81
Short circuit braking torque at nominal rotational speed ²⁾	$M_{\text{nom, sc}}$	Nm	43
Short circuit current at nominal speed ²⁾	$I_{\text{nom, sc}}$	A _{RMS}	136
Maximum short circuit braking torque ²⁾	$M_{\text{max, sc}}$	Nm	487
Maximum short circuit current ²⁾	$I_{\text{max, sc}}$	A _{RMS}	136
DC supply voltage	V_{DC}	V	700
Voltage for motor phases (outer conductor-outer conductor – RMS)	V_{LL}	V _{RMS}	475

Electric	Symbol	Unit	Value
Number of poles			8
Phase-phase voltage constant at 20 °C	k_{EMK}	V _{RMS} / 1000 rpm	343.8
Torque constant at 25 °C	k_{T}	Nm / A _{RMS}	6.72
Synchronous inductance (d-axis) at rated current	L_{d}	mH	3.24
Synchronous inductance (q-axis) at rated current	L_{q}	mH	9.91
Stator winding resistance (phase) at 20 °C	R_{LL}	Ω	0.158
Cogging torque (unskewed)	M_{cog}	Nm	24.12
Torque ripple	$M_{\text{Pk-Pk}}$	Nm	17.91

1) For the S2 calculation, the starting temperature of the components is assumed to be 25 °C.

2) Magnet temperature at 20 °C

▼ **Torque EMS1-16L10**

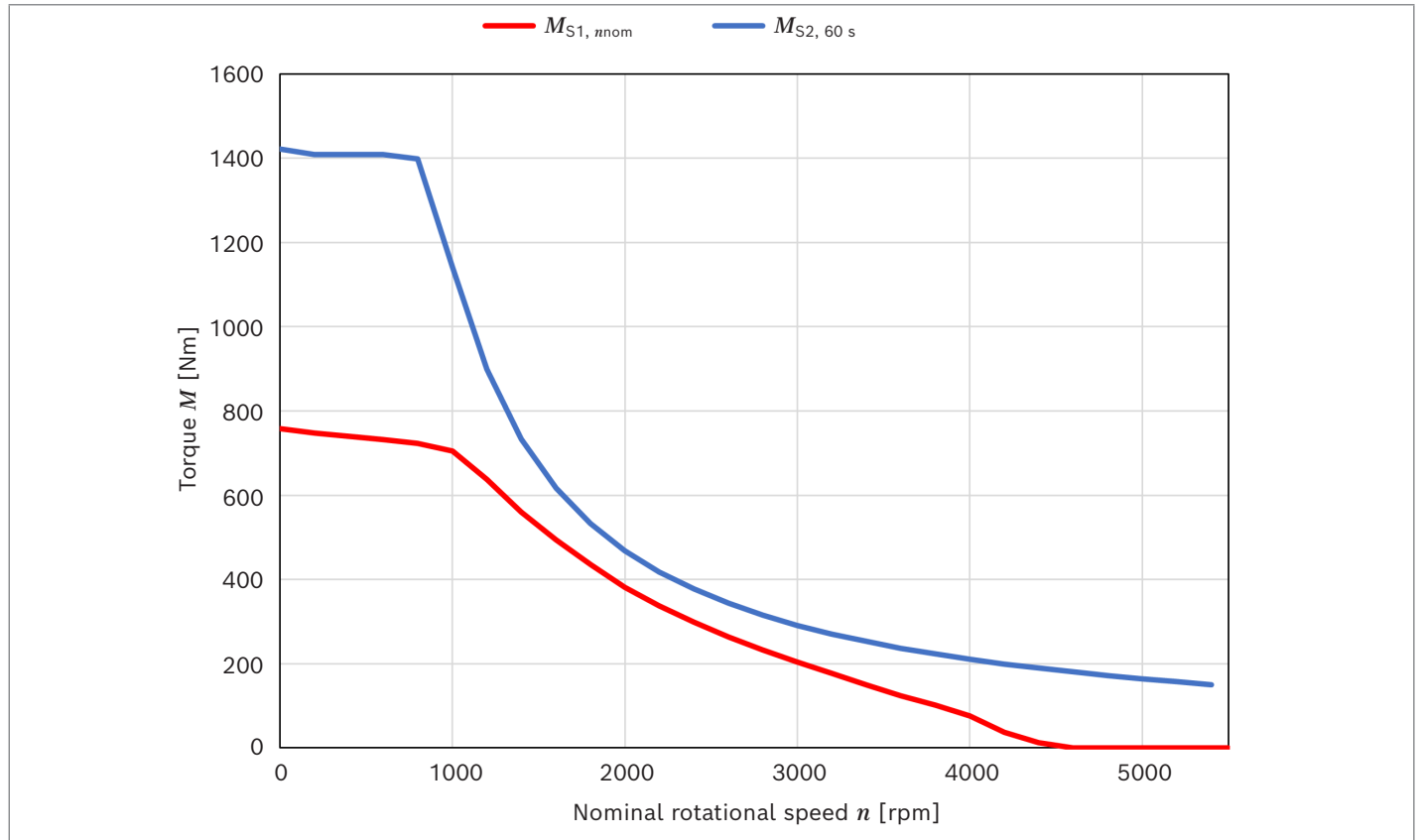

▼ **Power EMS1-16L10**

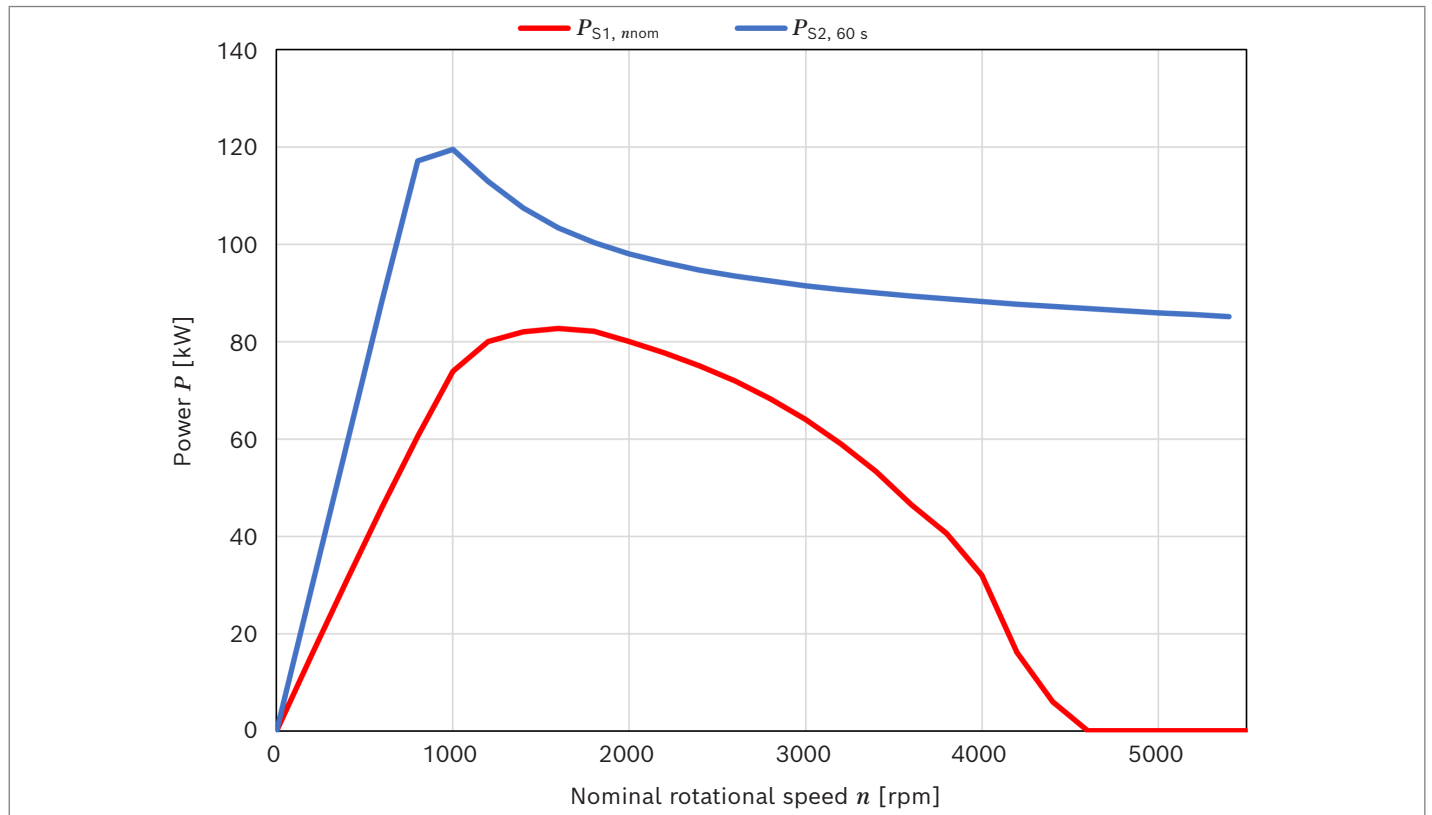

▼ Short circuit current and short circuit braking torque EMS1-16L10

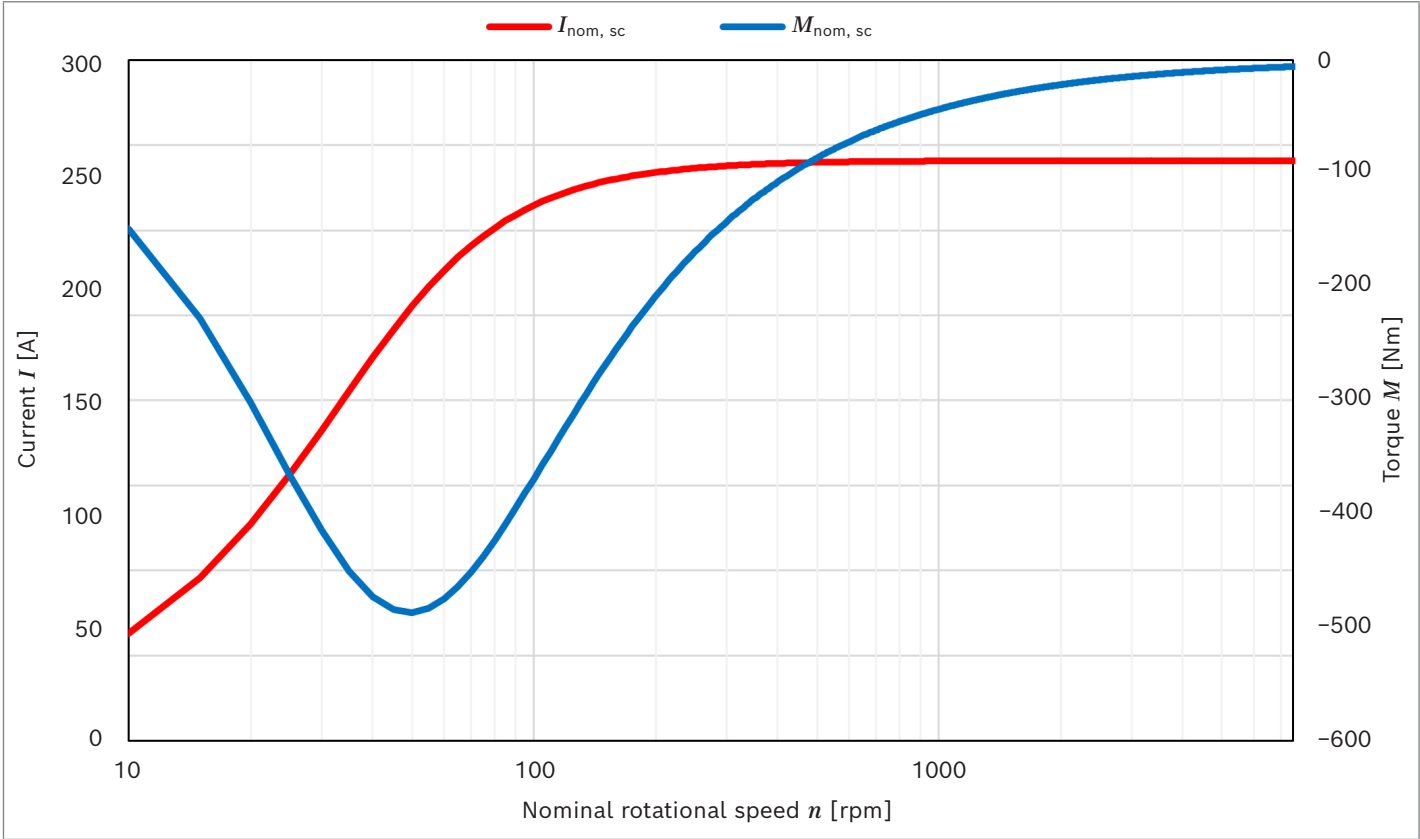

EMS1-16L15

Designation	Symbol	Unit	Value
S1 continuous torque at 200 rpm	$M_{S1, \text{ low rotational speed}}$	Nm	745
S1 continuous current at 200 rpm	$I_{S1, \text{ low rotational speed}}$	A _{RMS}	166
Nominal rotational speed	n_{nom}	rpm	1500
S1 continuous torque at n_{nom}	$M_{S1, n_{\text{nom}}}$	Nm	667
S1 continuous current at n_{nom}	$I_{S1, n_{\text{nom}}}$	A _{RMS}	155
S1 continuous power at n_{nom}	$P_{S1, n_{\text{nom}}}$	kW	105
S1 continuous efficiency at n_{nom}	$\eta_{S1, n_{\text{nom}}}$	%	94.88
S2 for 60s torque (maximum torque) ¹⁾	$M_{S2, 60 \text{ s}}$	Nm	1421
S2 for 60s current (maximum current) ¹⁾	$I_{S2, 60 \text{ s}}$	A _{RMS}	368
S2 for 60s power (maximum power) ¹⁾	$P_{S2, 60 \text{ s}}$	kW	178
Maximum rotational speed	n_{max}	rpm	5500
S1 continuous torque at n_{max}	$M_{S1, n_{\text{max}}}$	Nm	0
S1 continuous current at n_{max}	$I_{S1, n_{\text{max}}}$	A _{RMS}	0
S1 continuous power at n_{max}	$P_{S1, \text{ max}}$	kW	0
S1 continuous efficiency at n_{max}	$\eta_{S1, n_{\text{max}}}$	%	0.00
S1 continuous torque at $P_{S1, \text{ max}}$	$M_{S1, P_{\text{max}}}$	Nm	561
S1 continuous current at $P_{S1, \text{ max}}$	$I_{S1, P_{\text{max}}}$	A _{RMS}	151
S1 continuous power at $P_{S1, \text{ max}}$	$P_{S1, P_{\text{max}}}$	kW	113
S1 continuous speed at $P_{S1, \text{ max}}$	$n_{S1, P_{\text{max}}}$	%	1925
S1 continuous efficiency at $P_{S1, \text{ max}}$	$\eta_{S1, P_{\text{max}}}$	%	95.33
Short circuit braking torque at nominal rotational speed ²⁾	$M_{\text{nom, sc}}$	Nm	29
Short circuit current at nominal speed ²⁾	$I_{\text{nom, sc}}$	A _{RMS}	197
Maximum short circuit braking torque ²⁾	$M_{\text{max, sc}}$	Nm	487
Maximum short circuit current ²⁾	$I_{\text{max, sc}}$	A _{RMS}	197
DC supply voltage	V_{DC}	V	700
Voltage for motor phases (outer conductor-outer conductor – RMS)	V_{LL}	V _{RMS}	475

Electric	Symbol	Unit	Value
Number of poles			8
Phase-phase voltage constant at 20 °C	k_{EMK}	V _{RMS} /1000 rpm	238
Torque constant at 25 °C	k_{T}	Nm/A _{RMS}	4.66
Synchronous inductance (d-axis) at rated current	L_{d}	mH	1.56
Synchronous inductance (q-axis) at rated current	L_{q}	mH	4.82
Stator winding resistance (phase) at 20 °C	R_{LL}	Ω	0.0764
Cogging torque (unskewed)	M_{cog}	Nm	24.12
Torque ripple	$M_{\text{Pk-Pk}}$	Nm	17.15

1) For the S2 calculation, the starting temperature of the components is assumed to be 25 °C.

2) Magnet temperature at 20 °C

▼ Torque EMS1-16L15

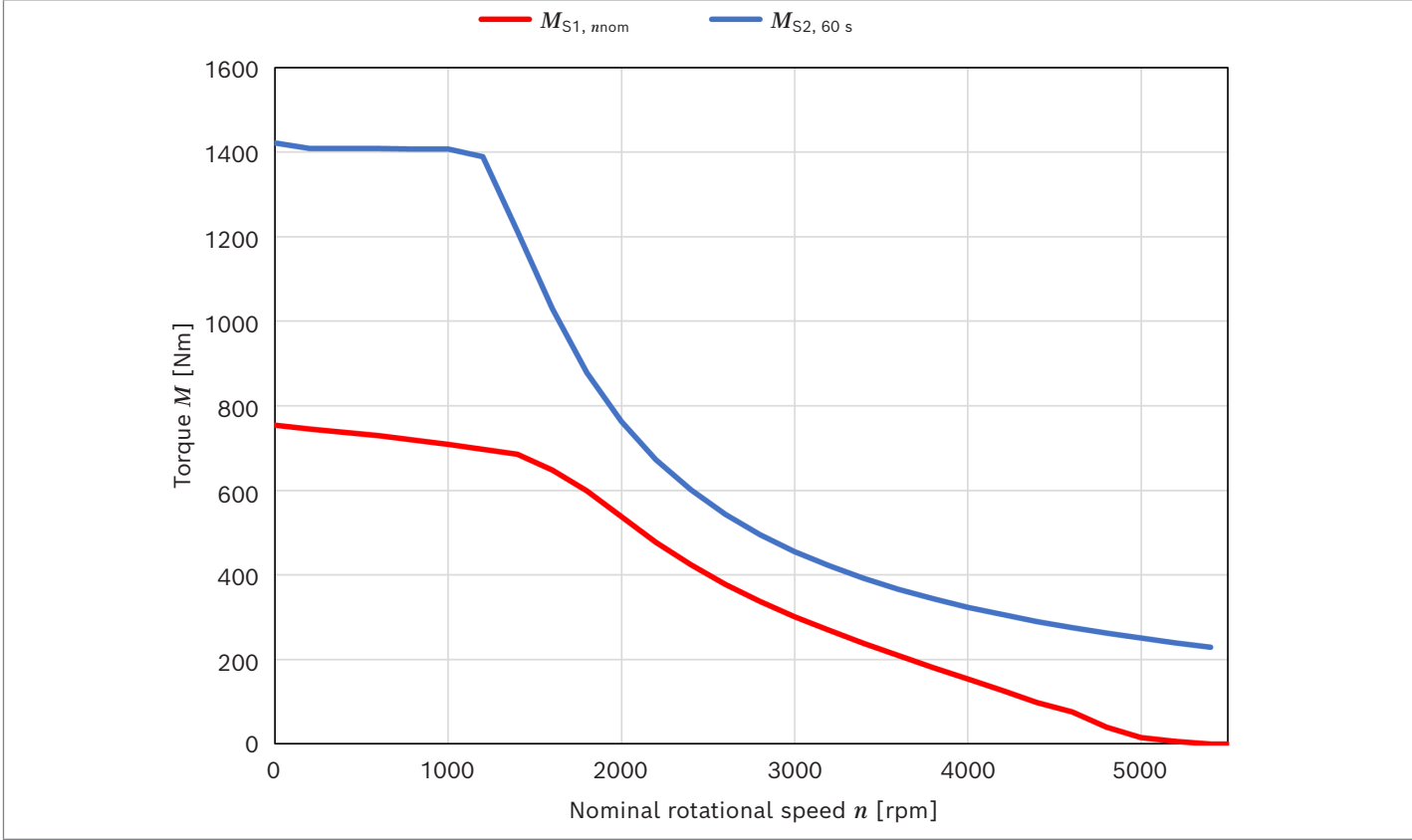

▼ Power EMS1-16L15

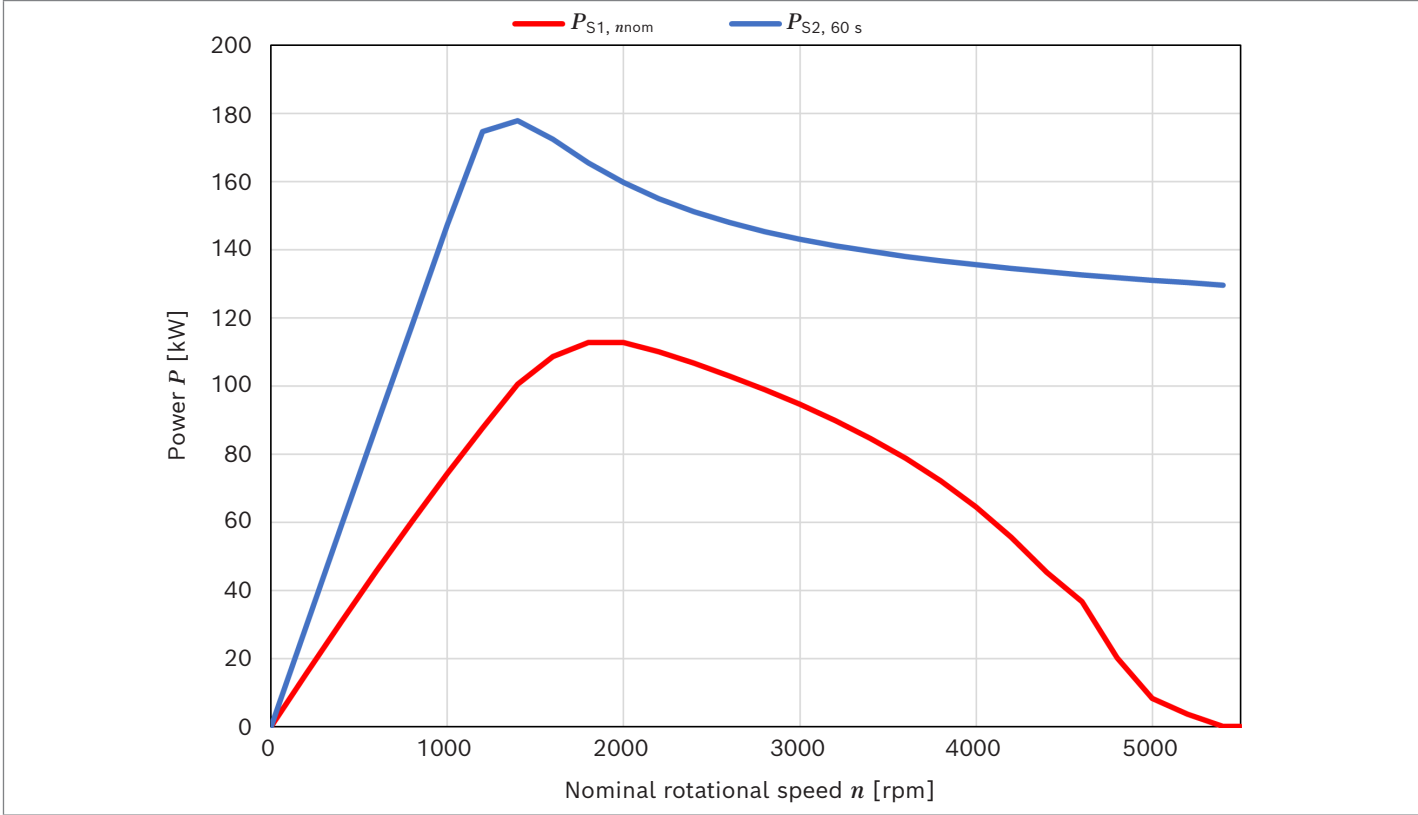

▼ **Short circuit current and short circuit braking torque EMS1-16L15**

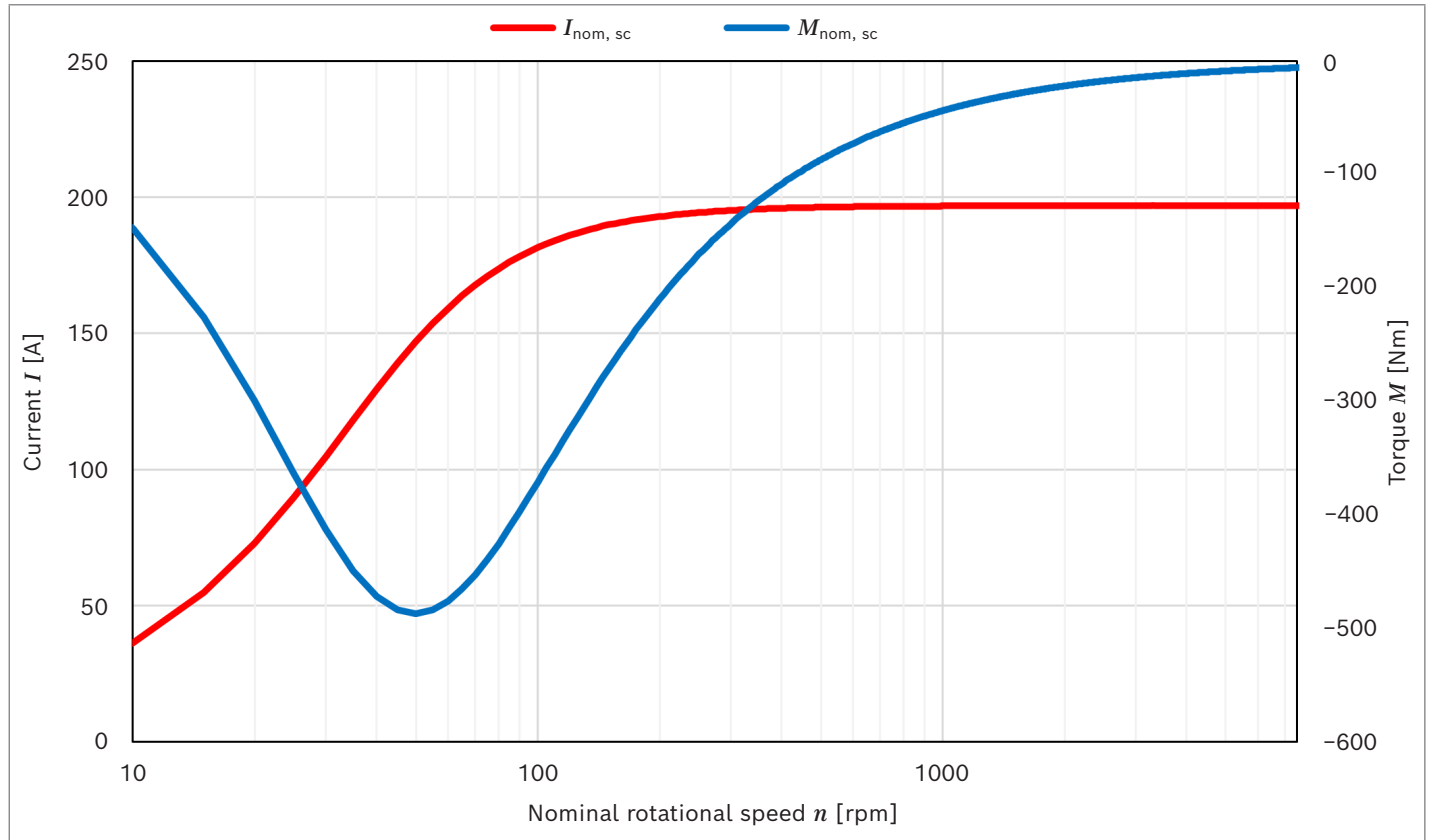

EMS1-16L20

Designation	Symbol	Unit	Value
S1 continuous torque at 200 rpm	$M_{S1, \text{low rotational speed}}$	Nm	748
S1 continuous current at 200 rpm	$I_{S1, \text{low rotational speed}}$	A _{RMS}	231
Nominal rotational speed	n_{nom}	rpm	2000
S1 continuous torque at n_{nom}	$M_{S1, n_{\text{nom}}}$	Nm	647
S1 continuous current at n_{nom}	$I_{S1, n_{\text{nom}}}$	A _{RMS}	204
S1 continuous power at n_{nom}	$P_{S1, n_{\text{nom}}}$	kW	136
S1 continuous efficiency at n_{nom}	$\eta_{S1, n_{\text{nom}}}$	%	95.93
S2 for 60s torque (maximum torque) ¹⁾	$M_{S2, 60 \text{ s}}$	Nm	1421
S2 for 60s current (maximum current) ¹⁾	$I_{S2, 60 \text{ s}}$	A _{RMS}	509
S2 for 60s power (maximum power) ¹⁾	$P_{S2, 60 \text{ s}}$	kW	250
Maximum rotational speed	n_{max}	rpm	5500
S1 continuous torque at n_{max}	$M_{S1, n_{\text{max}}}$	Nm	75
S1 continuous current at n_{max}	$I_{S1, n_{\text{max}}}$	A _{RMS}	107
S1 continuous power at n_{max}	$P_{S1, n_{\text{max}}}$	kW	43
S1 continuous efficiency at n_{max}	$\eta_{S1, n_{\text{max}}}$	%	91.02
S1 continuous torque at $P_{S1, \text{max}}$	$M_{S1, P_{\text{max}}}$	Nm	556
S1 continuous current at $P_{S1, \text{max}}$	$I_{S1, P_{\text{max}}}$	A _{RMS}	190
S1 continuous power at $P_{S1, \text{max}}$	$P_{S1, P_{\text{max}}}$	kW	141
S1 continuous speed at $P_{S1, \text{max}}$	$n_{S1, P_{\text{max}}}$	%	2420
S1 continuous efficiency at $P_{S1, \text{max}}$	$\eta_{S1, P_{\text{max}}}$	%	96.32
Short circuit braking torque at nominal rotational speed ²⁾	$M_{\text{nom, sc}}$	Nm	22
Short circuit current at nominal speed ²⁾	$I_{\text{nom, sc}}$	A _{RMS}	273
Maximum short circuit braking torque ²⁾	$M_{\text{max, sc}}$	Nm	487
Maximum short circuit current ²⁾	$I_{\text{max, sc}}$	A _{RMS}	273
DC supply voltage	V_{DC}	V	700
Voltage for motor phases (outer conductor-outer conductor – RMS)	V_{LL}	V _{RMS}	475

Electric	Symbol	Unit	Value
Number of poles			8
Phase-phase voltage constant at 20 °C	k_{EMK}	V _{RMS} /1000 rpm	171.9
Torque constant at 25 °C	k_{T}	Nm / A _{RMS}	3.36
Synchronous inductance (d-axis) at rated current	L_{d}	mH	0.82
Synchronous inductance (q-axis) at rated current	L_{q}	mH	2.54
Stator winding resistance (phase) at 20 °C	R_{LL}	Ω	0.0394
Cogging torque (unskewed)	M_{cog}	Nm	24.12
Torque ripple	$M_{\text{Pk-Pk}}$	Nm	16.56

1) For the S2 calculation, the starting temperature of the components is assumed to be 25 °C.

2) Magnet temperature at 20 °C

▼ **Torque EMS1-16L20**

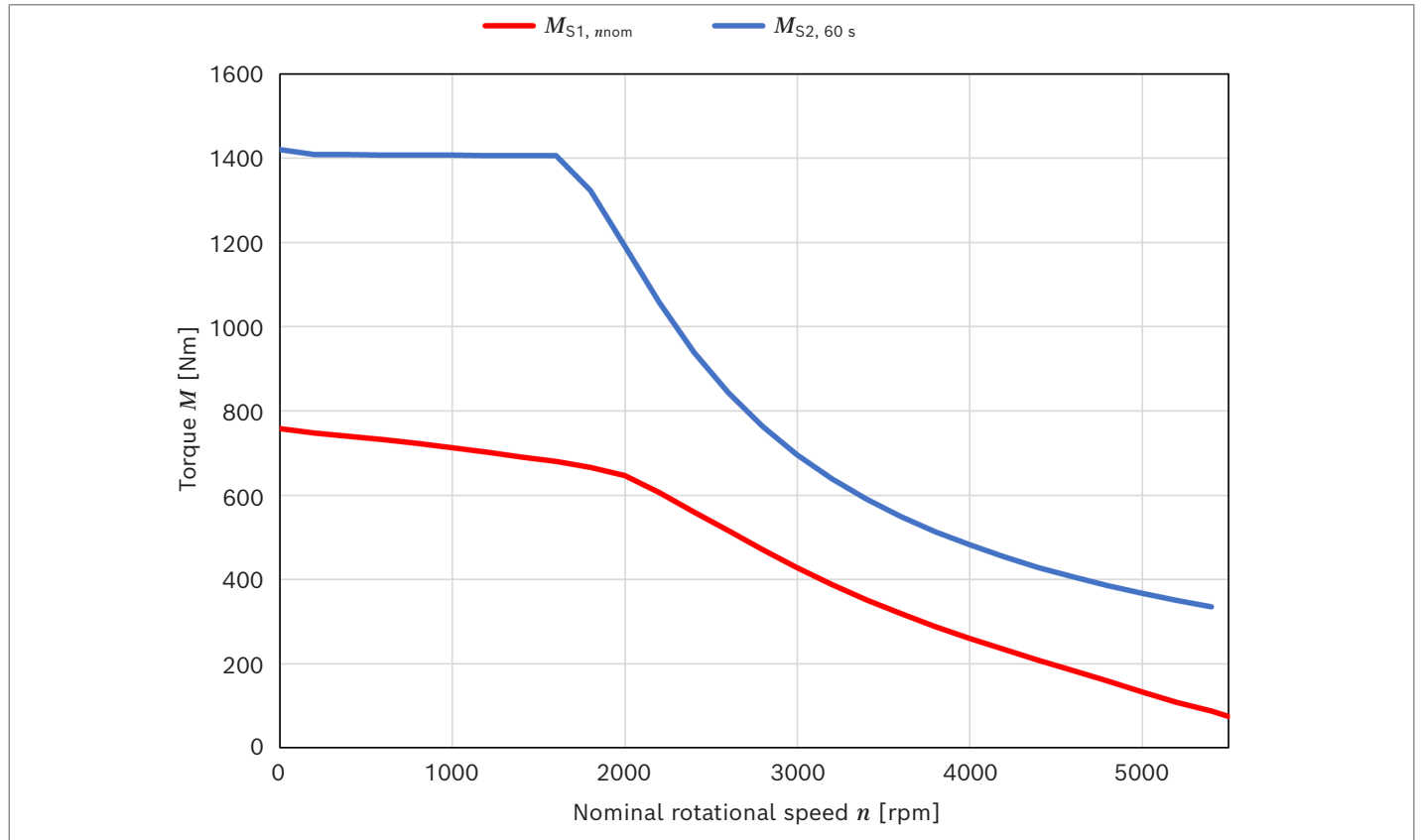

▼ **Power EMS1-16L20**

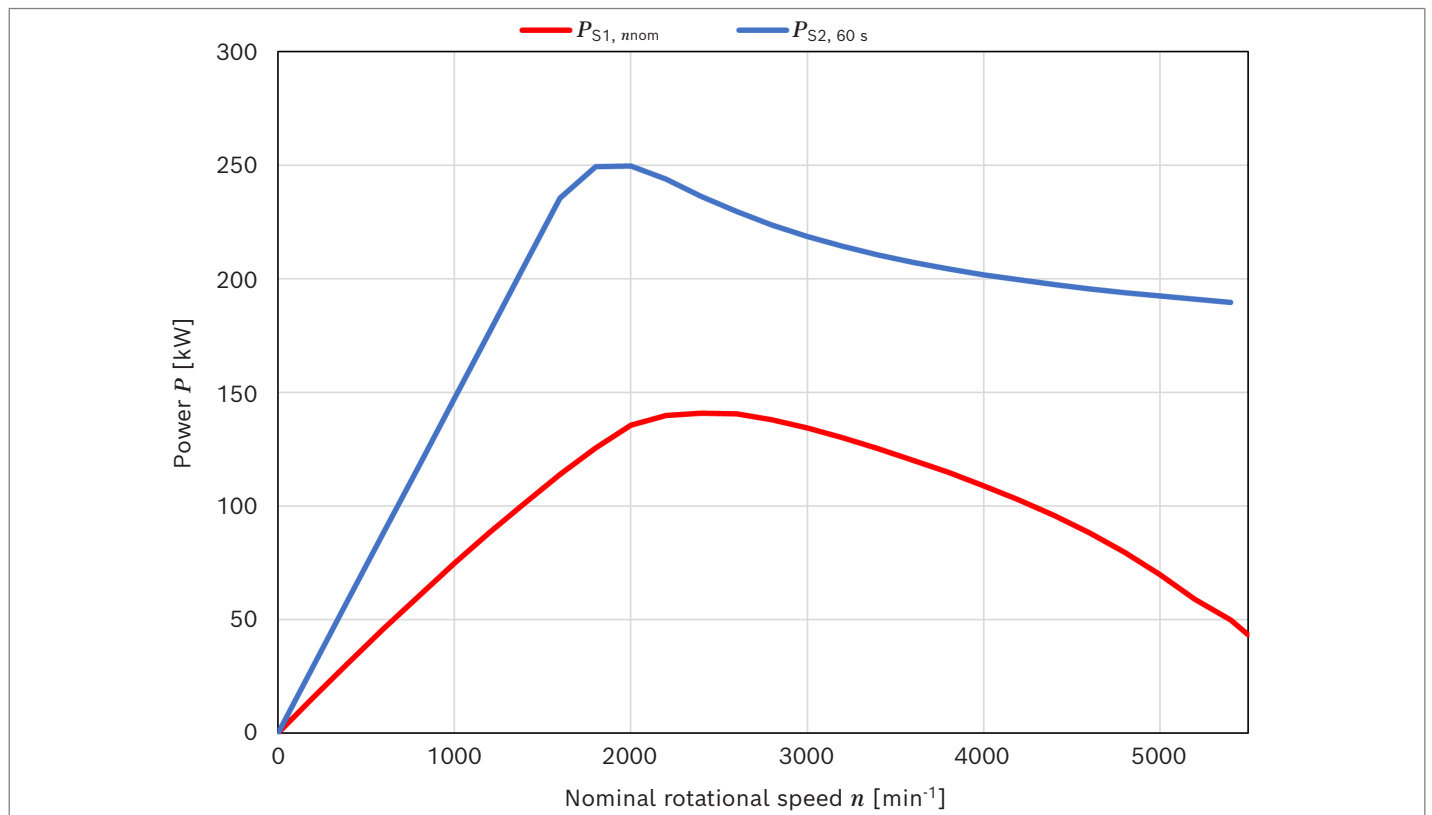

▼ Short circuit current and short circuit braking torque EMS1-16L20

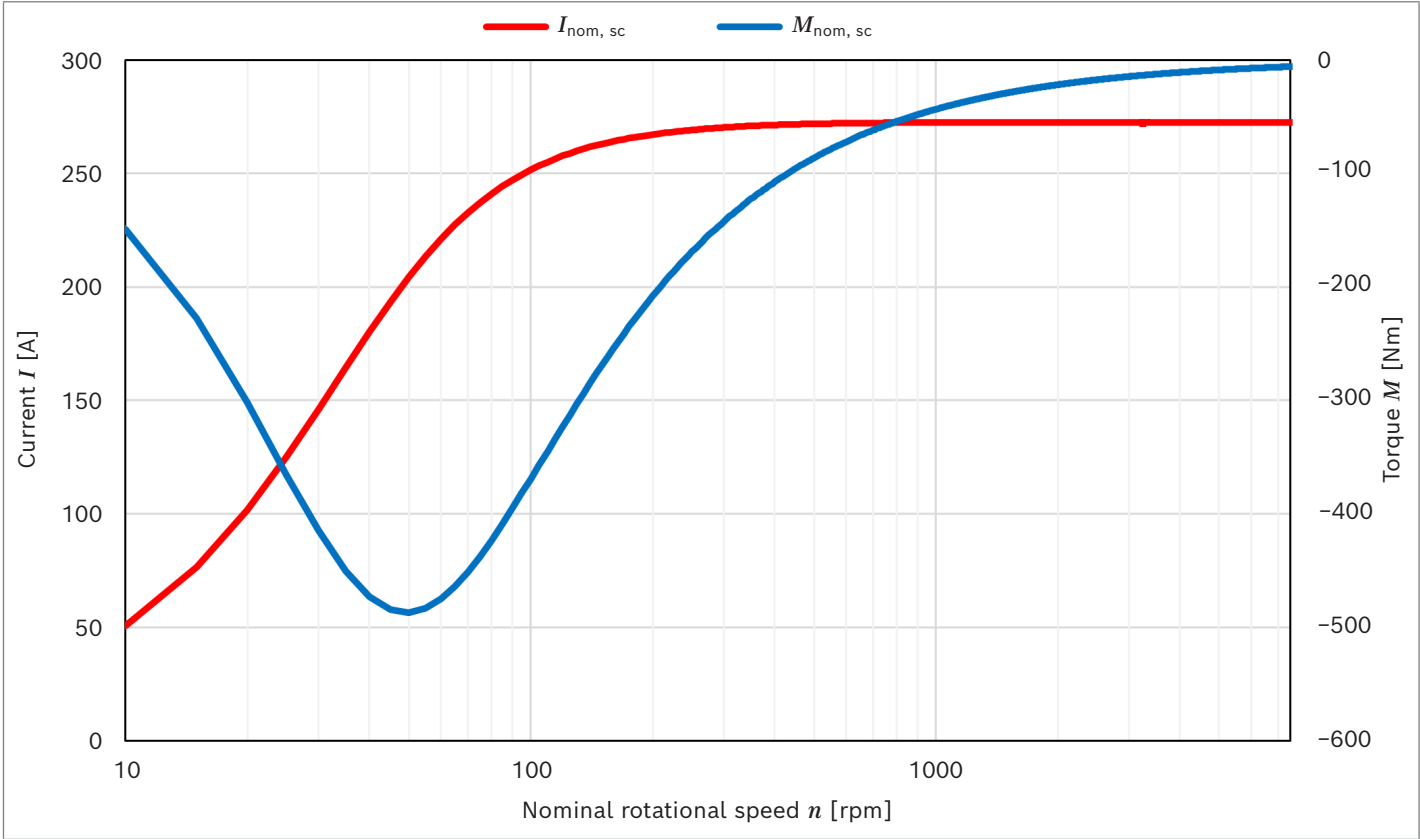

EMS1-16L25

Designation	Symbol	Unit	Value
S1 continuous torque at 200 rpm	$M_{S1, \text{ low rotational speed}}$	Nm	729
S1 continuous current at 200 rpm	$I_{S1, \text{ low rotational speed}}$	A _{RMS}	266
Nominal rotational speed	n_{nom}	rpm	2500
S1 continuous torque at n_{nom}	$M_{S1, n_{\text{nom}}}$	Nm	541
S1 continuous current at n_{nom}	$I_{S1, n_{\text{nom}}}$	A _{RMS}	206
S1 continuous power at n_{nom}	$P_{S1, n_{\text{nom}}}$	kW	142
S1 continuous efficiency at n_{nom}	$\eta_{S1, n_{\text{nom}}}$	%	96.45
S2 for 60s torque (maximum torque) ¹⁾	$M_{S2, 60 \text{ s}}$	Nm	1421
S2 for 60s current (maximum current) ¹⁾	$I_{S2, 60 \text{ s}}$	A _{RMS}	601
S2 for 60s power (maximum power) ¹⁾	$P_{S2, 60 \text{ s}}$	kW	297
Maximum rotational speed	n_{max}	rpm	5500
S1 continuous torque at n_{max}	$M_{S1, n_{\text{max}}}$	Nm	112
S1 continuous current at n_{max}	$I_{S1, n_{\text{max}}}$	A _{RMS}	117
S1 continuous power at n_{max}	$P_{S1, \text{ max}}$	kW	65
S1 continuous efficiency at n_{max}	$\eta_{S1, n_{\text{max}}}$	%	94.05
S1 continuous torque at $P_{S1, \text{ max}}$	$M_{S1, P_{\text{max}}}$	Nm	501
S1 continuous current at $P_{S1, \text{ max}}$	$I_{S1, P_{\text{max}}}$	A _{RMS}	197
S1 continuous power at $P_{S1, \text{ max}}$	$P_{S1, P_{\text{max}}}$	kW	144
S1 continuous speed at $P_{S1, \text{ max}}$	$n_{S1, P_{\text{max}}}$	%	2750
S1 continuous efficiency at $P_{S1, \text{ max}}$	$\eta_{S1, P_{\text{max}}}$	%	96.64
Short circuit braking torque at nominal rotational speed ²⁾	$M_{\text{nom, sc}}$	Nm	17
Short circuit current at nominal speed ²⁾	$I_{\text{nom, sc}}$	A _{RMS}	322
Maximum short circuit braking torque ²⁾	$M_{\text{max, sc}}$	Nm	487
Maximum short circuit current ²⁾	$I_{\text{max, sc}}$	A _{RMS}	322
DC supply voltage	V_{DC}	V	700
Voltage for motor phases (outer conductor-outer conductor – RMS)	V_{LL}	V _{RMS}	475

Electric	Symbol	Unit	Value
Number of poles			8
Phase-phase voltage constant at 20 °C	k_{EMK}	V _{RMS} /1000 rpm	145.5
Torque constant at 25 °C	k_{T}	Nm/A _{RMS}	2.83
Synchronous inductance (d-axis) at rated current	L_{d}	mH	0.6
Synchronous inductance (q-axis) at rated current	L_{q}	mH	1.93
Stator winding resistance (phase) at 20 °C	R_{LL}	Ω	0.0285
Cogging torque (unskewed)	M_{cog}	Nm	24.12
Torque ripple	$M_{\text{Pk-Pk}}$	Nm	12.93

1) For the S2 calculation, the starting temperature of the components is assumed to be 25 °C.

2) Magnet temperature at 20 °C

▼ **Torque EMS1-16L25**

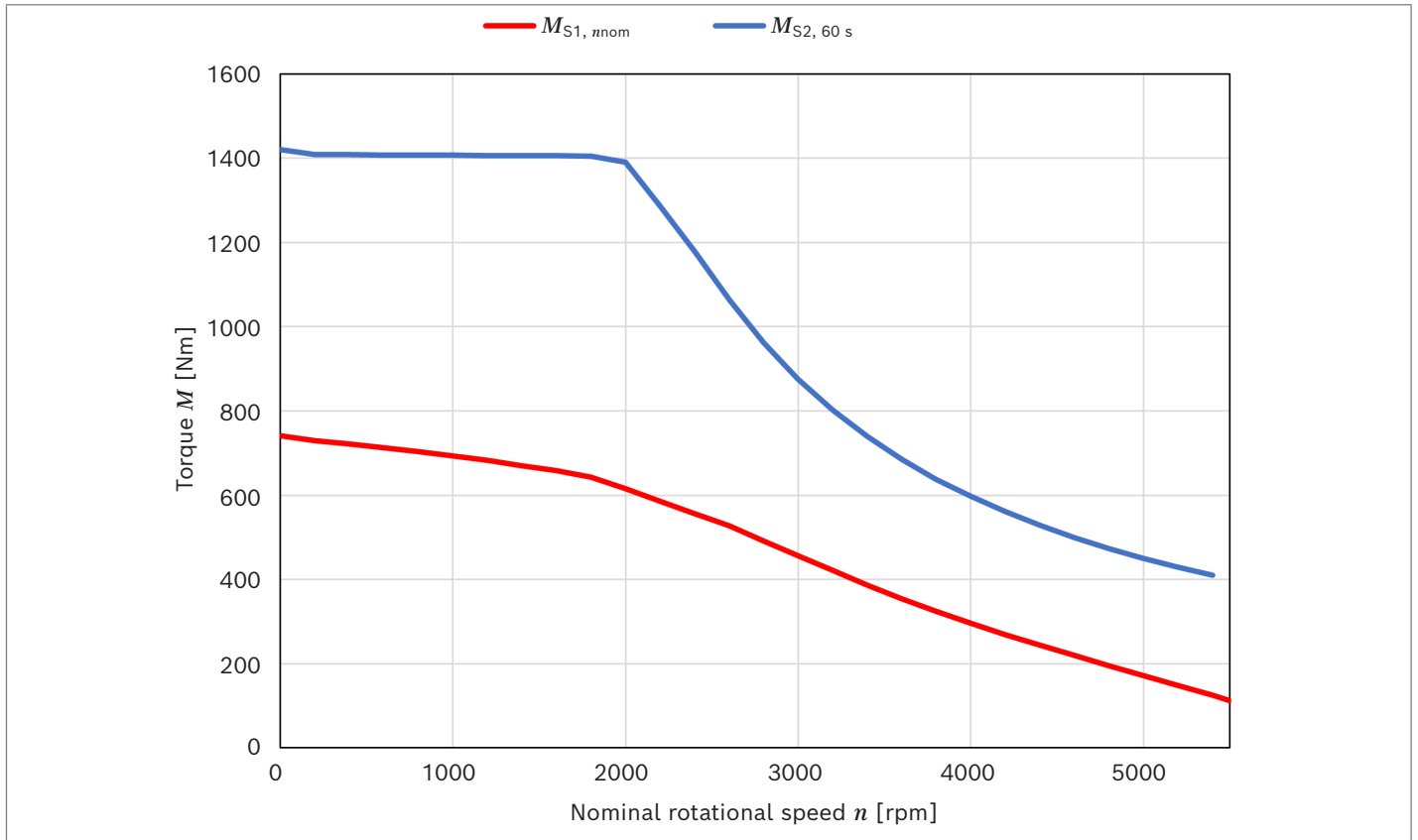

▼ **Power EMS1-16L25**

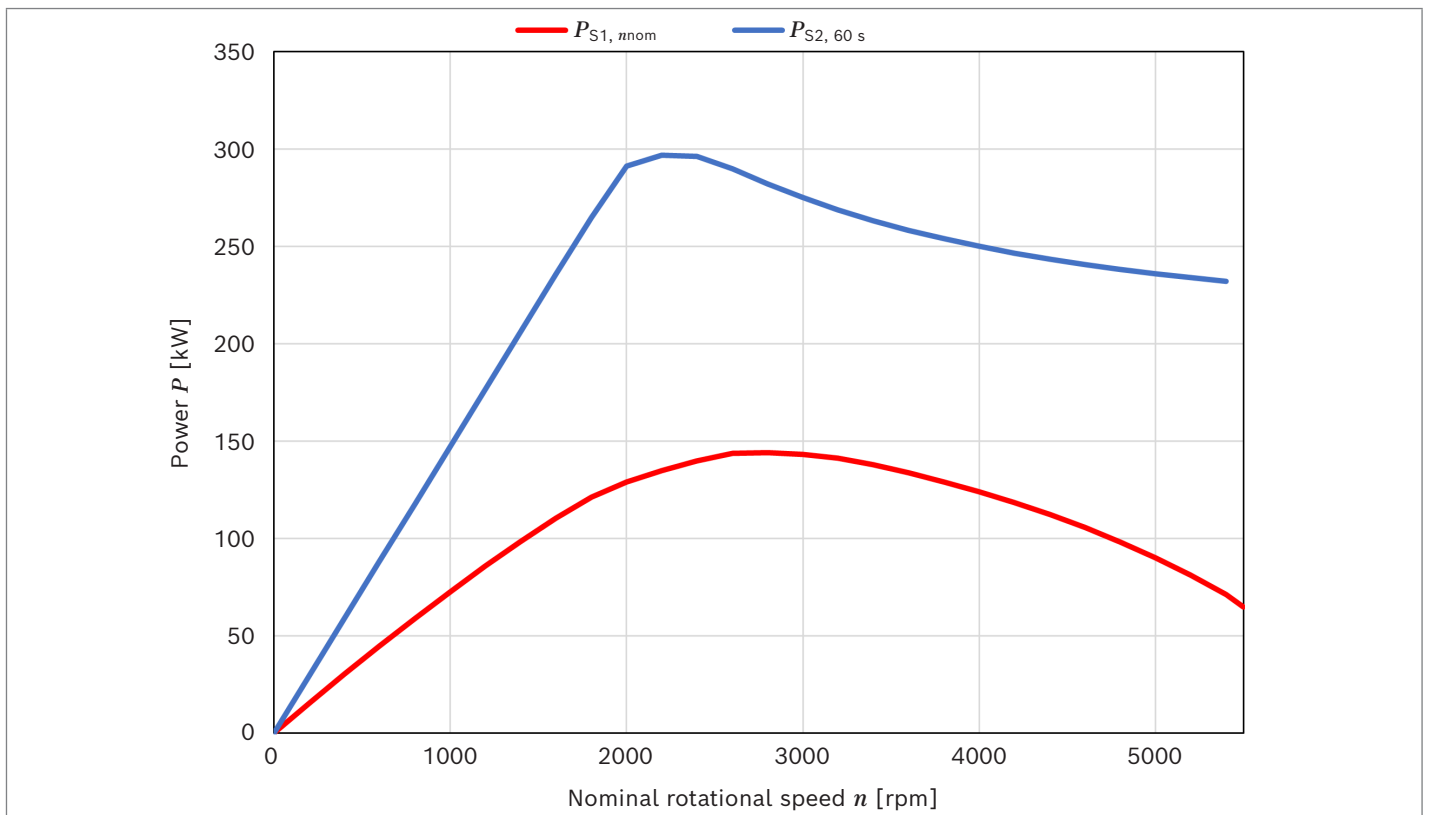

▼ **Short circuit current and short circuit braking torque EMS1-16L25**

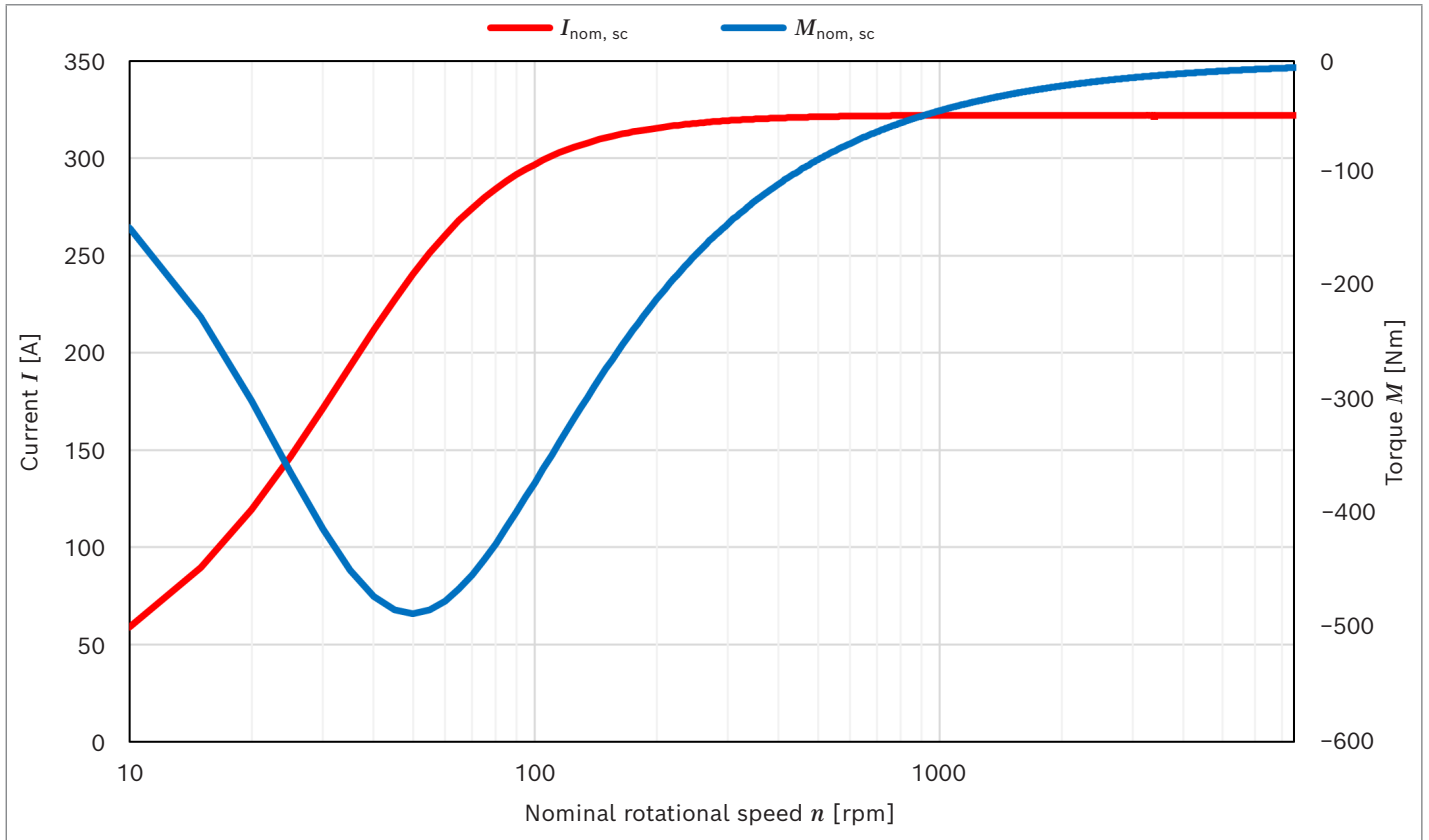

Sensor

Resolver

The built-in resolver detects the position of the rotor. This position is used by the corresponding inverter to calculate the motor rotational speed and to correctly set the stator currents.

Parameter	Unit	EMS1-16
Ambient temperature	°C	-40 ... 150
Storage temperature	°C	-40 ... 80
Excitation voltage	V _{RMS}	7
Excitation frequency	kHz	10
Ohmic output load (symmetrical)	kΩ	450
Output capacitance	μF	100
Polarity		4 Pole
Gear ratio		0.286 ±10 %
Input impedance at 10 kHz, 7 V _{RMS}	Ω	75±12 %
Sine output impedance at 10 kHz, 7 V _{RMS}	Ω	175±20 %
Cosine output impedance at 10 kHz, 7 V _{RMS}	Ω	175±20 %
Angle error range		<120 arc minutes (degrees)
Phase shift	°	±15
Maximum operating speed	rpm	20000

Temperature sensor

The eLION motors have two PT1000 temperature sensors for thermal protection. One PT1000 is used to measure the stator winding temperature and the second PT1000 is used to measure the inlet temperature of the cooling liquid.

Notice

Due to their thermal inertia, the sensors are not able to follow rapid changes in the winding temperature. In this case, please note the maximum permissible current and the thermal motor model of the inverter EDS1.

▼ **PT1000 characteristics**

With the PT1000 temperature sensors, the temperature of the winding and the cooling liquid can be constantly monitored. We recommend setting the winding warning temperature to 145 °C and the switch-off temperature to 175 °C.

Type	Unit	S2
Sensor		PT1000
Measuring range	°C	0 ... 200
R_0	Ω	1000
Temperature tolerance	K	± 5 (B)
Recommended measuring current	mA	< 1
Dielectric insulation strength	kV	2

▼ **Resistance table PT1000**

Temperature [°C]	R [Ω]
0	1000
25	1097
50	1194
75	1290
100	1385
125	1480
150	1573
175	1666
200	1759

▼ **Resistance characteristic curve PT1000**

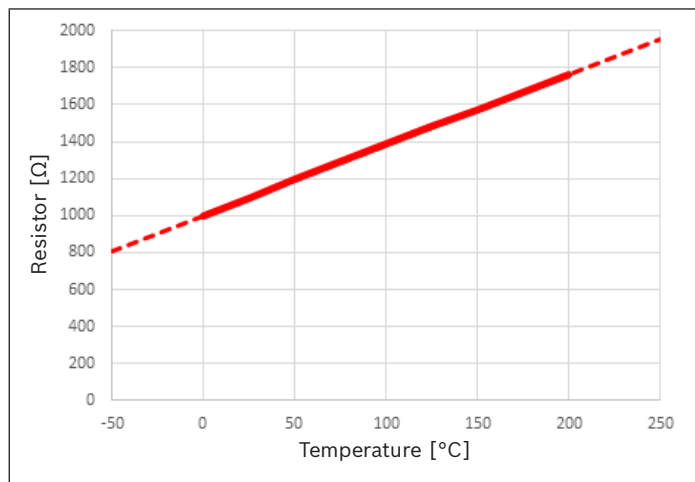

Electrical connections

Terminal box

See operating instructions 96709-01-B

XG23, LV motor encoder and temperature connector

See operating instructions 96709-01-B

Operating ranges and characteristic curves

▼ Motor operating ranges (EM)

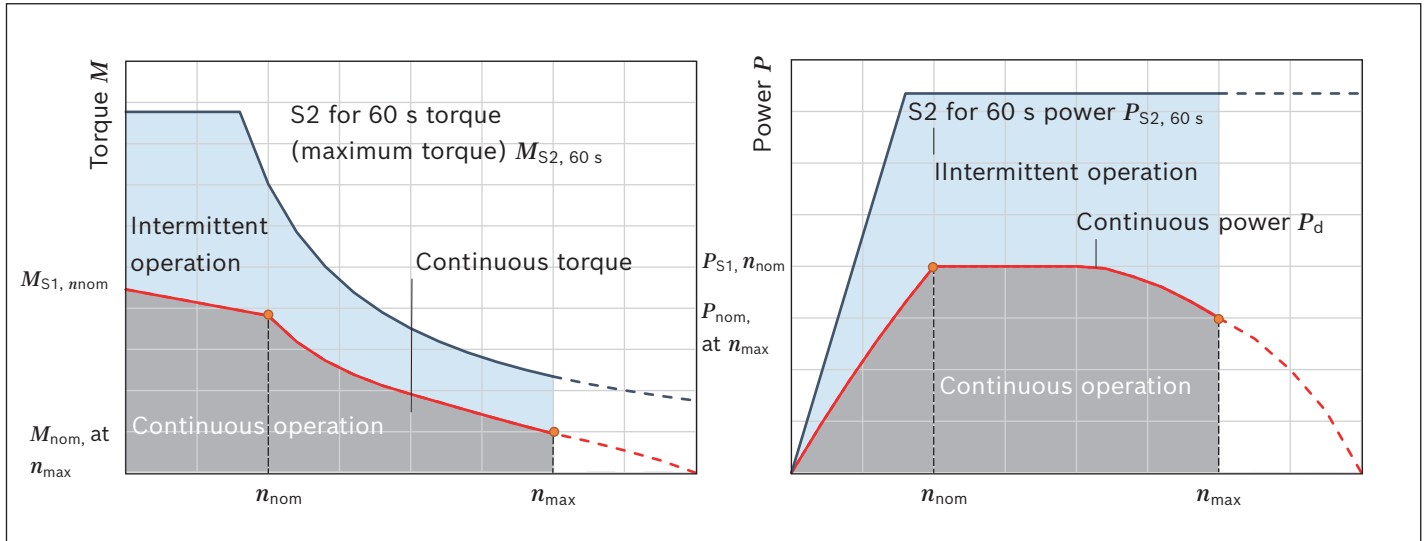

- ▶ S1 continuous torque $M_{S1, n_{nom}}$ [Nm]:
Continuous torque available at nominal rotational speed n_{nom} and a cooling liquid inlet temperature of 65 °C.
- ▶ Operating modes:
The operating modes of electric motor generators are defined according to VDE 0530 “Rules for motor generators”. Operation includes the specification of the motor generator load including duration, sequence and, if applicable, starting, electrical braking, idling, and interruptions.
 - S1 (continuous operation according to DIN EN 60034-1):
Operation under constant load, the duration of which is sufficient to achieve the thermally stationary state.
 - S3 (periodic intermittent operation according to DIN 60034-1):
Periodic intermittent operation comprises a sequence of similar cycles at constant nominal load and standstill period. The start-up current has no measurable effect on the temperature increase. The relative duty cycle is equal to the load time divided by (load time plus standstill period) multiplied by 100%.
 - Continuous operation:
Operation under constant load. In this mode, the motor generator does not reach the thermally stationary state. The torque and power are therefore lower than in S1 operation, as a temporary overload reserve is maintained.
 - Intermittent operation
Operating points that cause damage and excessive wear in the long term, and are therefore limited in their permissible duration.
- ▶ Continuous torque:
Torque that is constantly available (see “Continuous operation”).
- ▶ S2 for 60 s torque $M_{S2, 60 s}$ [Nm]:
Temporary maximum torque applied at operating temperature with nominal load. $M_{S2, 60 s}$ is defined according to ECE R85 with a component start-up temperature of 25 °C and a coolant inlet temperature of 65 °C. After that, the machine can only be operated with a torque that is not above the continuous torque. If a torque higher than the continuous torque is requested again, the motor load must be lower than the continuous torque to allow the motor to cool down. The lower the load on the motor, the shorter the cooling time. This limitation is for thermal reasons.
- ▶ Maximum rotational speed n_{max} [rpm]:
Maximum mechanically permissible rotational speed of the motor. Limiting factors for EMS1 motors are the maximum permissible bearing speeds to maintain the service life of the motor.
- ▶ Nominal rotational speed n_{nom} [rpm]:
Rotational speed specified by the manufacturer for the specifications of the nominal data on the name plate. The rotational speed is achieved at a DC voltage of 700 V.

Dimensions

▼ **EMS1-16 with terminal box, externally toothed shaft W50×2×24×8c, motor flange SAE4 (variant W3M4)**

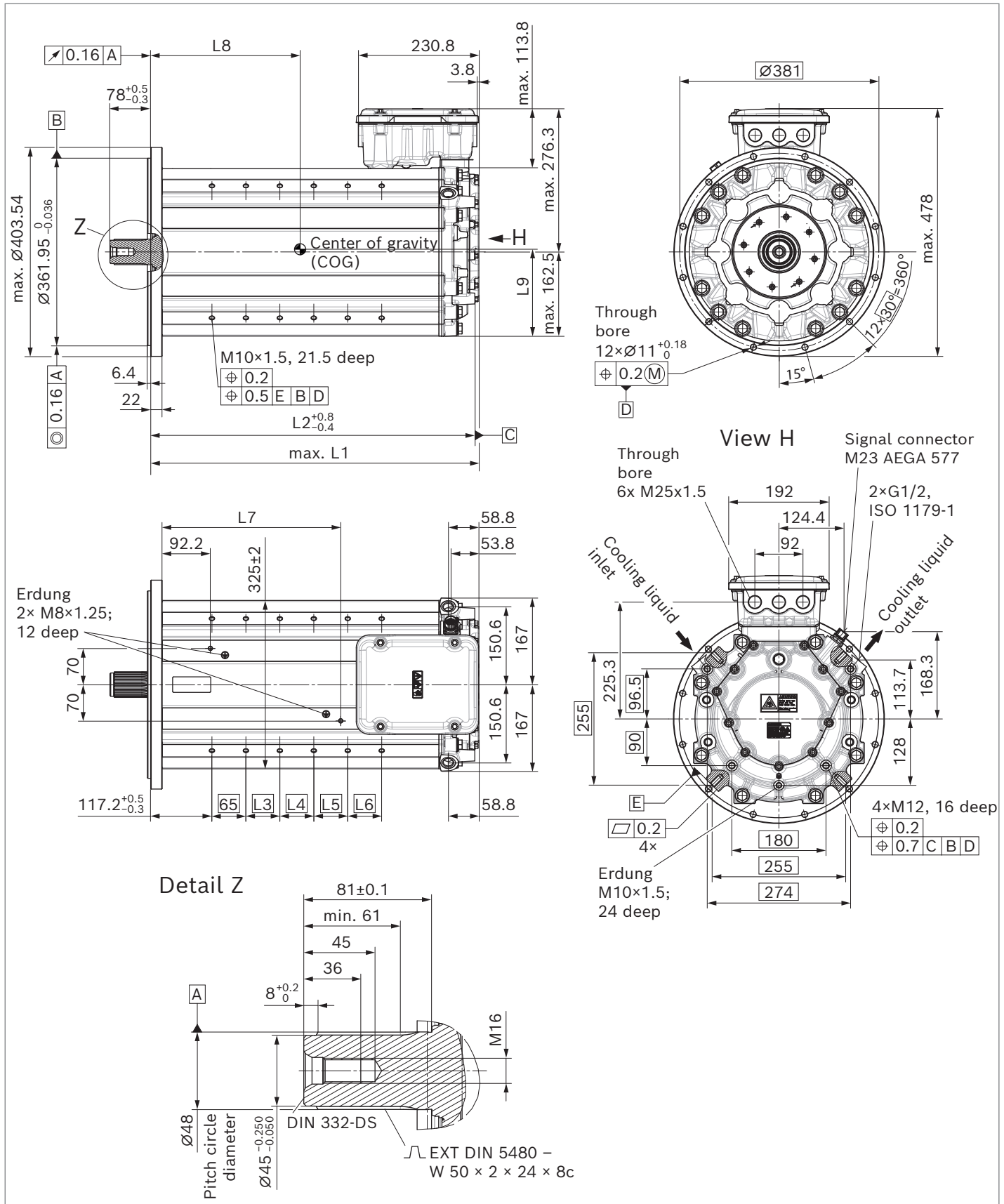

	L1	L2	L3	L4	L5	L6	L7	L8	L9	N	m
EMS1-16FXXLM7-RSAB-W3M4	448.2	440.5	65	45	–	–	161.7	200	170	16	179 kg
EMS1-16HXXLM7-RSAB-W3M4	508.2	500.5	65	65	–	–	221.7	230	170	16	209 kg
EMS1-16JXXLM7-RSAB-W3M4	568.2	560.5	65	65	65	–	281.7	260	169	20	239 kg
EMS1-16LXXLM7-RSAB-W3M4	628.2	620.5	65	65	65	65	341.7	290	168	24	269 kg

▼ **EMS1-16 with terminal box, internal-splined shaft N1 1/4 14T 12/24 DP, pump flange SAE C4/C2 (variant N2P7)**

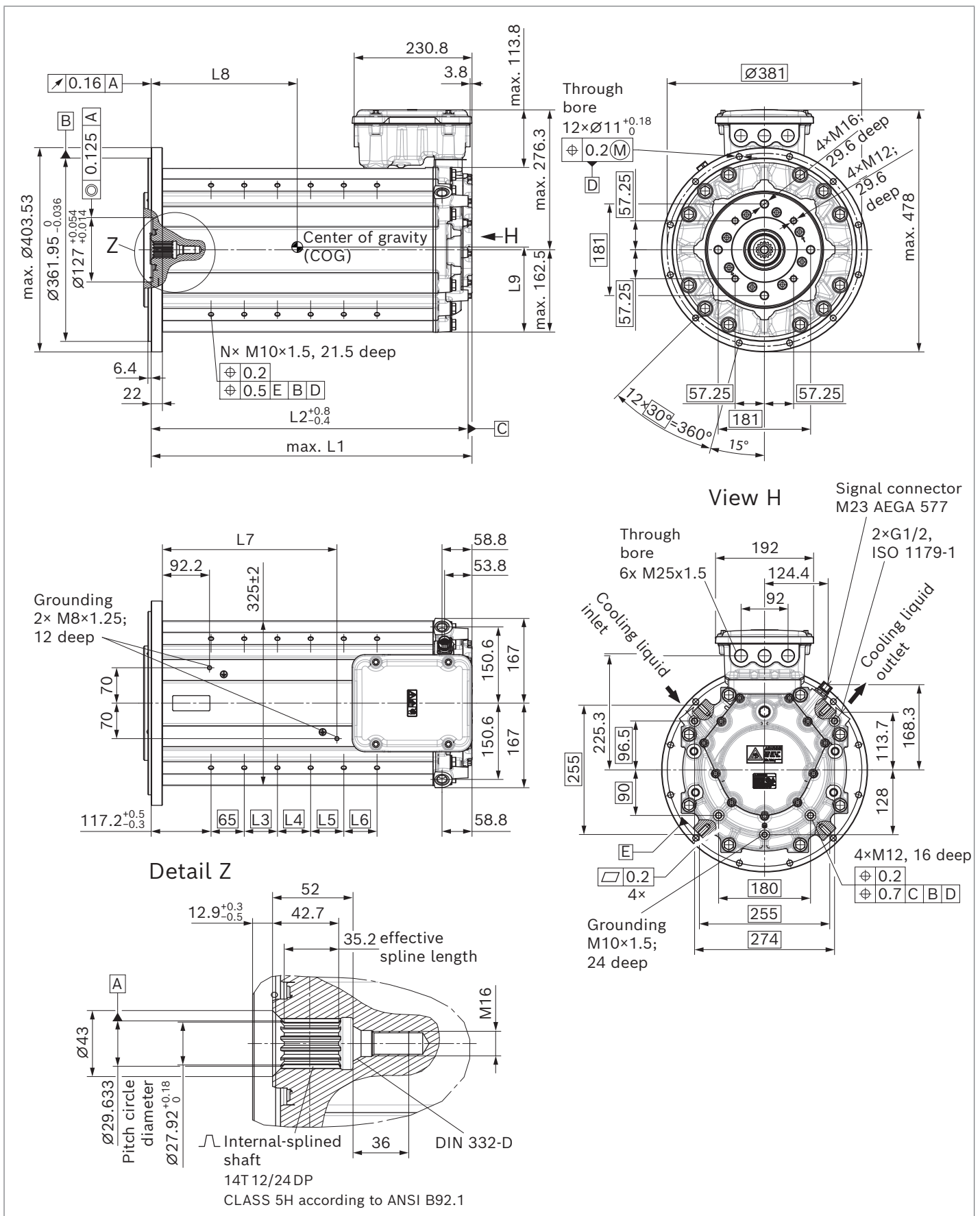

	L1	L2	L3	L4	L5	L6	L7	L8	L9	N	m
EMS1-16FXXLM7-RSAB-N2P7	448.2	440.5	65	45	–	–	161.7	196.5	170	16	182 kg
EMS1-16HXXLM7-RSAB-N2P7	508.2	500.5	65	65	–	–	221.7	226	169.5	16	212 kg
EMS1-16JXXLM7-RSAB-N2P7	568.2	560.5	65	65	65	–	281.7	256	168.5	20	242 kg
EMS1-16LXXLM7-RSAB-N2P7	628.2	620.5	65	65	65	65	341.7	286	168	24	272 kg

▼ **EMS1-16 with terminal box, internal-splined shaft N13/4 13T8/16 DP, pump flange SAE D4 (variant N4P8)**

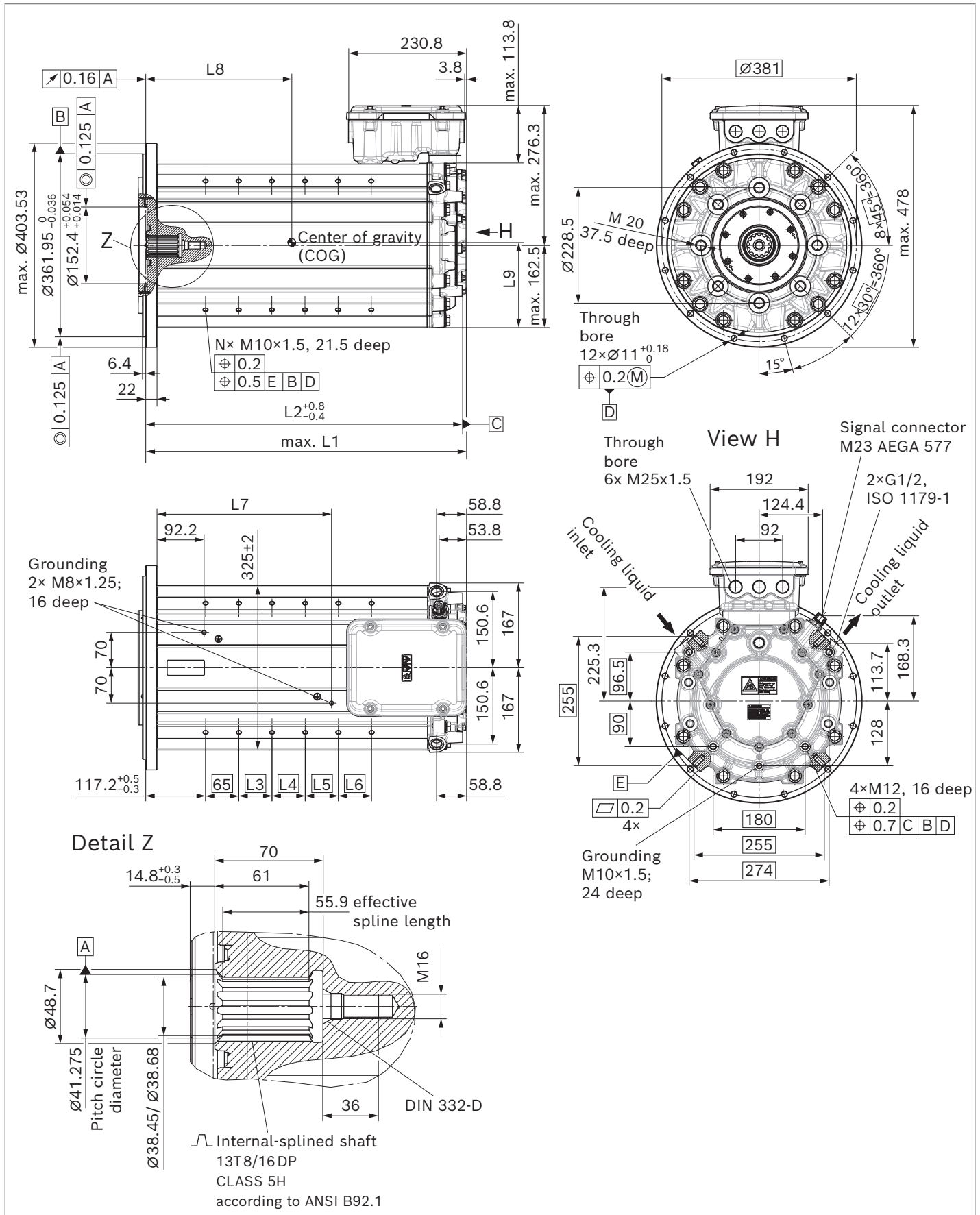

	L1	L2	L3	L4	L5	L6	L7	L8	L9	N	m
EMS1-16FXXLM7-RSAB-N4P8	448.2	440.5	65	45	–	–	161.7	196.5	170	16	179 kg
EMS1-16HXXLM7-RSAB-N4P8	508.2	500.5	65	65	–	–	221.7	226	169.5	16	209 kg
EMS1-16JXXLM7-RSAB-N4P8	568.2	560.5	65	65	65	–	281.7	256	168.5	20	239 kg
EMS1-16LXXLM7-RSAB-N4P8	628.2	620.5	65	65	65	65	341.7	286	168	24	269 kg

Mounting type

See “Operating Instructions 96709-01-B”

General

- ▶ Read the corresponding “Operating Instructions 96709-01-B” completely and thoroughly before using the motor. If necessary, this can be requested from Bosch Rexroth.
- ▶ Despite the greatest care being taken when compiling this document, it is impossible to consider all feasible applications. If information for your specific application is missing, please contact Bosch Rexroth.
- ▶ For further information about the motor, visit www.boschrexroth.com/elion-motors.

Bosch Rexroth AG

Glockeraustraße 2
89275 Elchingen
Germany
Tel. +49 7308 82-0
info.ma@boschrexroth.de
www.boschrexroth.com

© Bosch Rexroth AG 2026. All rights reserved, also regarding any disposal, exploitation, reproduction, editing, distribution, as well as in the event of applications for industrial property rights. The data specified within only serve to describe the product. As our products are constantly being further developed, no statements concerning a certain condition or suitability for a certain application can be derived from our information. The information given does not release the user from the obligation of own judgment and verification. It must be remembered that our products are subject to a natural process of wear and aging.